

User's Manual

LG Programmable Logic Controller

GLOFA G3F - AD4A
G4F - AD2A

LG Industrial Systems

© CONTENTS ©

Chapter 1. INTRODUCTION

1.1 Features	1-1
1.1.1 G3F-AD4A	1-1
1.1.2 G4F-AD2A	1-1
1.2 Glossary	1-2
1.2.1 A-Analog Value	1-2
1.2.2 D-Digital Value	1-2
1.2.3 Analog / Digital Conversion Characteristics	1-3

Chapter 2. SPECIFICATIONS

2.1 General Specifications	2-1
2.2 Performance Specifications	2-2
2.3 Names of Parts and Functions	2-3
2.3.1 G3F-AD4A	2-3
2.3.2 G4F-AD2A	2-5
2.4 I/O Conversion Characteristics	2-6
2.4.1 G3F-AD4A I/O Characteristics	2-7
1) Voltage Input Characteristics	2-7
2) Current Input Characteristics	2-9
3) Simultaneous Voltage and Current Input Characteristics	2-10
2.4.2 G4F-AD2A I/O Characteristics	2-11
1) Voltage Input Characteristics	2-11
2) Current Input Characteristics	2-13
3) Simultaneous Voltage and Current Input Characteristics	2-14
2.4.3 Relations between Offset / Gain Setting and Digital Output Value	2-16
1) Resolution	2-16
2) Relations between Maximum Resolution and Digital Output Value	2-16
3) Offset / Gain Setting	2-17

(1) Offset / Gain Setting of the G3F-AD4A	2-17
(2) Offset / Gain Setting of the G4F-AD2A	2-19
2.5 A/D Conversion Characteristics	2-21
2.5.1 Filter Processing	2-21
2.5.2 Sampling Processing (Instantaneous Value)	2-21
2.5.3 Average Processing	2-22

Chapter 3. INSTALLATION AND WIRING

3.1 Installation	3-1
3.1.1 Installation Ambience	3-1
3.1.2 Handling Precautions	3-1
3.2 Wiring	3-2
3.2.1 Wiring Precautions	3-2
3.2.2 Wiring Examples	3-3
1) G3F-AD4A	3-3
2) G4F-AD2A	3-4

Chapter 4. TROUBLESHOOTING

4.1 Error Code	4-1
4.1.1 Error Code Indicated by RUN LED Flickering	4-1
4.2 Troubleshooting	4-2
4.2.1 RUN LED Flickering	4-2
4.2.2 RUN LED Off	4-2
4.2.3 Digital Value Unreadable from the CPU Module	4-3
4.2.4 Sudden Digital Value Change	4-3
4.2.5 Analog and Digital Value Mismatch	4-4
4.2.6 A/D Conversion Module Hardware Fault	4-4

Chapter 5. DIMENSIONS

5.1 G3F-AD4A Dimensions	5-1
5.2 G4F-AD2A Dimensions	5-2

Chapter 6. FUNCTION BLOCK

6.1	Insertion of the Function Block for the A/D Conversion Module on the GMWIN	6-1
6.2	Local Function Block	6-2
6.2.1	Module Initialization (G3F-AD4A: AD4INI, G4F-AD2A: AD2INI)	6-2
6.2.2	Module Reading - Array Type (G3F-AD4A: AD4ARD, G4F-AD2A: AD2ARD)	6-3
6.2.3	Module Reading - Single Type (G3F-AD4A: AD4RD, G4F-AD2A: AD2RD)	6-4
6.3	Remote Function Block	6-5
6.3.1	Module Initialization (G3F-AD4A: AD4RINI, G4F-AD2A: ADR2INI)	6-5
6.3.2	Module Reading (G3F-AD4A: ADR4RD, G4F-AD2A: ADR2RD)	6-6
6.4	Errors on Function Block	6-7

Chapter 7. PROGRAMMING

7.1	Programming for Distinction of A/D Conversion Value	7-1
7.2	Programming for Display of A/D Conversion Value and Error Code on BCD Display...	7-6
7.3	Programming for Loading the A/D Conversion Module on Remote I/O Station	7-9



SAFETY PRECAUTIONS

Be sure to read carefully the safety precautions given in data sheet and user's manual before operating the module and follow them.

The precautions explained here only apply to the G3F-AD4A and G4F-AD2A.

For safety precautions on the PLC system, see the GLOFA GM3/4 User's Manuals.

A precaution is given with a hazard alert triangular symbol to call your attention, and precautions are represented as follows according to the degree of hazard.

 WARNING	⇒	If not provided with proper prevention, it can cause death or fatal injury or considerable loss of property.
 CAUTION	⇒	If not properly observed, it can cause a hazard situation to result in severe or slight injury or a loss of property.

However, a precaution followed with  **CAUTION** can also result in serious conditions.

Both of two symbols indicate that an important content is mentioned, therefore, be sure to observe it.

Keep this manual handy for your quick reference in necessary.

Design Precautions

CAUTION

- ▶ Do not run I/O signal lines near to high voltage line or power line. Separate them as 100 mm or more as possible. Otherwise, noise can cause module malfunction.

Installation Precautions

CAUTION

- ▶ Operate the PLC in the environment conditions given in the general specifications.
- ▶ If operated in other environment not specified in the general specifications, it can cause an electric shock, a fire, malfunction or damage or degradation of the module
- ▶ Make sure the module fixing projections is inserted into the module fixing hole and fixed.
- ▶ Improper installation of the module can cause malfunction, disorder or falling.

Wiring Precautions



CAUTION

- ▶ When grounding a FG terminal, be sure to provide class 3 grounding which is dedicated to the PLC.
- ▶ Before the PLC wiring, be sure to check the rated voltage and terminal arrangement for the module and observe them correctly.
If a different power, not of the rated voltage, is applied or wrong wiring is provided, it can cause a fire or disorder of the module.
- ▶ Drive the terminal screws firmly to the defined torque.
If loosely driven, it can cause short circuit, a fire or malfunction.
- ▶ Be careful that any foreign matter like wire scraps should not enter into the module.
It can cause a fire, disorder or malfunction.

Test Run and Maintenance Precautions



WARNING

- ▶ Do not contact the terminals while the power is applied.
It can cause malfunction.
- ▶ When cleaning or driving a terminal screw, perform them after the power has been turned off
- ▶ Do not perform works while the power is applied, which can cause disorder or malfunction.



CAUTION

- ▶ Do not separate the module from the printed circuit board(PCB), or do not remodel the module.
They can cause disorder, malfunction, damage of the module or a fire.
When mounting or dismantling the module, perform them after the power has been turned off.
- ▶ Do not perform works while the power is applied, which can cause disorder or malfunction.

Waste Disposal Precautions



CAUTION

- ▶ When disposing the module, do it as an industrial waste.

Chapter 1. INTRODUCTION

The G4F-AD2A and the G3F-AD4A are analog/digital conversion modules for use with the GLOFA PLC GM 1/2/3/4 series CPU module. The G4F-AD2A is used on GM4 series module, and the G3F-AD4A is used on the GM1/2/3 series module. (Hereafter the G4F-AD2A and G3F-AD4A are called the A/D conversion module) The A/D conversion module is to convert an analog input signal (voltage or current) from external sensors into a 16-bit signed BIN (Binary) digital value.

1.1 Features

1.1.1 G3F-AD4A

1) 16-Channel analog to digital conversion is possible with a single module.

The G3F-AD4A has 16-Channel A/D conversion capacity, with each channel selectable for voltage or current input.

2) High resolution of 1/16000

High-resolution digital values can be obtained. Resolution setting applies to all channels.

3) A/D conversion values display.

The LED display shows a digital value or an error code as a 5-digit decimal.

4) The number of the G3F-AD4A used on one base is unlimited.

1.1.2 G4F-AD2A

1) 4-Channel analog to digital conversion is possible with a single module.

The G4F-AD2A has 4-Channel A/D conversion capacity, with each channel selectable for voltage or current input.

2) High resolution of 1/16000

High-resolution digital values can be obtained. Resolution setting applies to all channels.

3) The number of the G4F-AD2A used on one base is unlimited.

1.2 Glossary

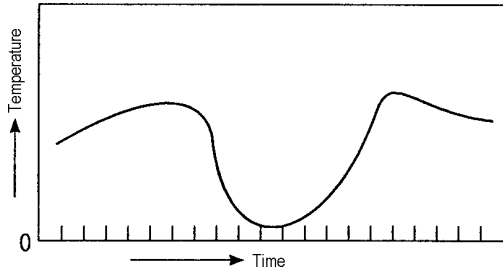

[Fig 1.1] Analog Value

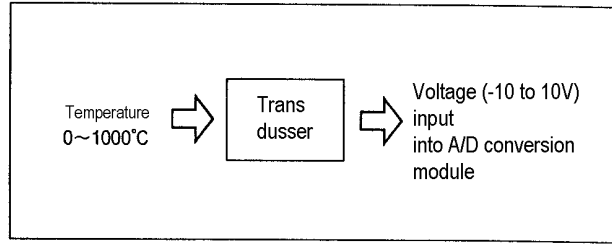

[Fig 1.2] Transducer

1.2.1 A-Analog Value

Analog value is a sequentially changing value such as voltage, current, temperature, speed, pressure, flux, etc. Temperature, for example, is sequentially changing according to the time. Because this temperature is not input on the PLC through transducer, the same analog value of DC voltage (0 to ± 10 V) or current (4 to 20 mA) in accordance with the temperature should be inputted on the PLC.

1.2.2 D-Digital Value

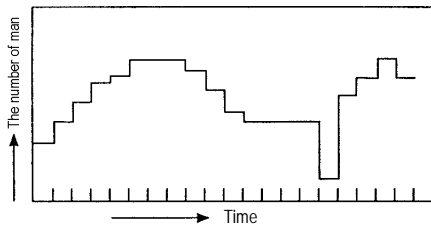

[Fig 1.3] Digital Value

Digital value is non-sequentially changing value written as the number like 0, 1, 2, 3. The signal of on or off is written as digital value of 0 or 1. There are BCD value and binary value in the range of digital value.

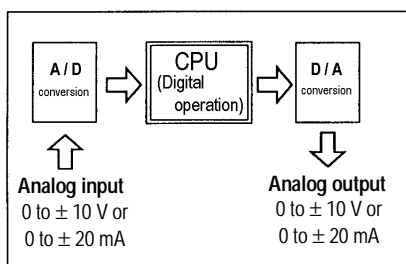

[Fig 1.4] PLC Processing

Analog value isn't written directly onto the CPU. For analog input to the CPU operation, analog converted to digital value has to be inputted onto the CPU and for analog output, the digital value of the CPU should be converted to analog value.

1.2.3 Analog/ Digital Conversion Characteristics

1) Voltage input

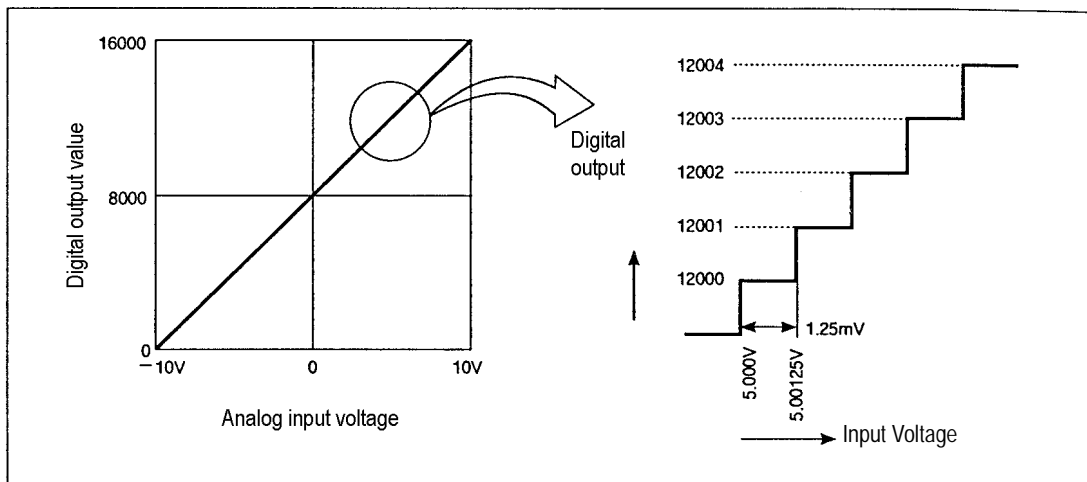

[Fig 1.5] A/D Conversion Characteristics (Voltage Input)

Analog/digital conversion module allows external analog input to be converted to digital value and to be operated in the CPU. On voltage input, input of -10 V leads to digital value of 0 and 10 V to 16000. Input of 1.25 mV is equal to digital value of 1. Therefore, input less than 1.25 mV shouldn't be converted but ignored.

2) Current input

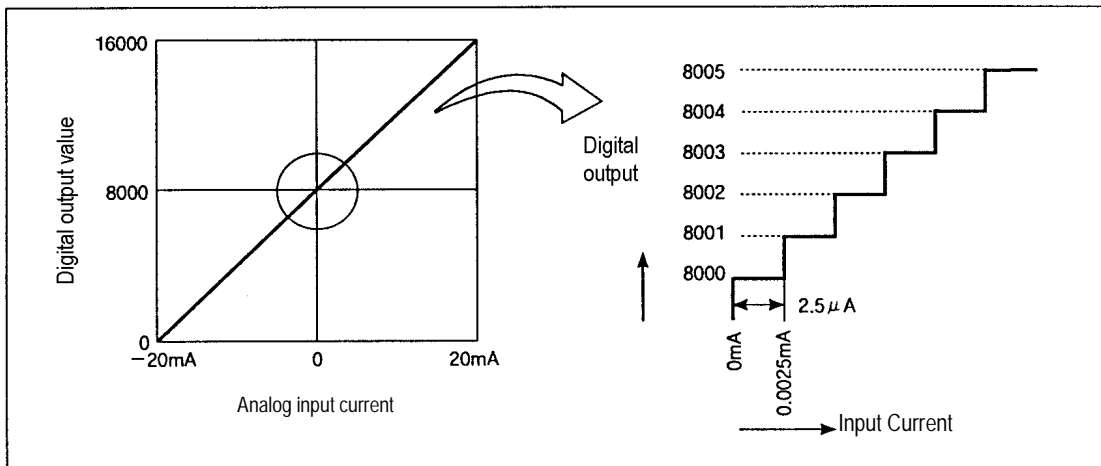

[Fig 1.6] A/D Conversion Characteristics (Current input)

On current input, input of -20 mA leads to digital value of 8000 and 20 mA to 16000. Input of $2.5\mu\text{A}$ is equal to digital value of 1. Therefore, input less than $2.5\mu\text{A}$ shouldn't be converted but ignored.

Chapter 2 . SPECIFICATIONS

2.1 General Specifications

Table 2.1 shows the general specifications of GLOFA GM series.

No	Item	Specifications	Standard				
1	Operating ambient temperature	0 ~ 55℃					
2	Storage ambient temperature	-25 ~ 70℃					
3	Operating ambient humidity	5 ~ 95%RH, non-condensing					
4	Storage ambient humidity	5 ~ 95%RH, non-condensing					
5	Vibration	Occasional vibration		10 times in each direction for X, Y, Z	IEC 1131-2		
		Frequency	Acceleration			Amplitude	Sweep count
		$10 \leq f < 57$ Hz	-			0.075 mm	
		$57 \leq f \leq 150$ Hz	9.8 m/s^2 {1G}			-	
		Continuous vibration					
		Frequency	Acceleration			Amplitude	
		$10 \leq f < 57$ Hz	-			0.035 mm	
		$57 \leq f \leq 150$ Hz	4.9 m/s^2 {0.5G}				
6	Shocks	*Maximum shock acceleration: 147 m/s^2 {15G} *Duration time :11 ms *Pulse wave: half sine wave pulse(3 times in each of X, Y and Z directions)	IEC 1131-2				
7	Noise immunity	Square wave impulse noise	$\pm 1,500$ V				
		Electrostatic discharge	Voltage :4kV(contact discharge)	IEC 1131-2 IEC 801-2			
		Radiated electromagnetic field	27 ~ 500 MHz, 10 V/m	IEC 1131-2 IEC 801-3			
		Fast transient burst noise	Severity Level	All power modules	Digital I/Os ($U_e < 24$ V) Analog I/Os communication I/Os	IEC 1131-2 IEC 801-4	
Voltage	2 kV		1 kV	0.25 kV			
8	Operating atmosphere	Free from corrosive gases and excessive dust					
9	Altitude for use	Up to 2,000m					
10	Pollution degree	2 or lower					
11	Cooling method	Self-cooling					

[Table 2.1] General specifications

REMARK

- 1) IEC(International Electrotechnical Commission)
: The international civilian organization which produces standards for electrical and electronics industry.
- 2) Pollution degree
: It indicates a standard of operating ambient pollution level.
The pollution degree 2 means the condition in which normally, only non-conductive pollution occurs.
Occasionally, however, a temporary conductivity caused by condensation shall be expected.

2.2 Performance Specifications

Table 2-2 shows performance specifications of A/D conversion module.

Items		Specifications	
		G3F-AD4A	G4F-AD2A
Analog input	Voltage	-5 ~ 5 VDC (input resistance 560k Ω) -10 ~ 10 VDC (input resistance 560k Ω)	
	Current	DC -20 ~ 20 mA (input resistance 250 Ω)	
	Voltage/Current selection	*. Select with the Input conversion switch on the side of the module (on: current, off: voltage) *. When current input is used, set the Input range switch to V1 / I.	*. Select in accordance with the Input terminals. *. Connect the V terminal with the I terminal on the use of current input.
Digital output		*. 16-bit (data: 14bit)signed binary *. May be set per channel by setting output data "0": -192 to 16191 "1": -8192 to 8191	
Maximum resolution	-5 ~ 5 VDC	0.625 mV (1/16000)	
	-10 ~ 10 VDC	1.25 mV (1/16000)	
	DC -20 ~20 mA	0.0025 mA (1/16000)	
Overall Accuracy(%)		$\pm 0.5\%$ or lower (accuracy to full scale) ($\pm 0.3\%$ at ambient temperature 25 $^{\circ}\text{C}$)	
Maximum conversion speed (ms/channel)		3.0	5.0
Maximum absolute input		Voltage(V): ± 12 , Current (mA): ± 25	
Number of analog input point		16 channels/module	4 channels/module
Isolation		Between input terminals and PLC: Photo coupler isolation (Between channels : Non-isolated)	
Terminals connected		38-point terminal block	20-point terminal block
Internal current consumption(A)		0.7 A	0.4 A
Weight (g)		630	360
LED Display		Digital output value or Error code is displayed	-

[Table 2.2] Performance Specifications

CAUTION

The factory set value to A/D conversion module has been in the range of the from -10 to 10 VDC, and in accordance with it, offset / gain values have already been set.





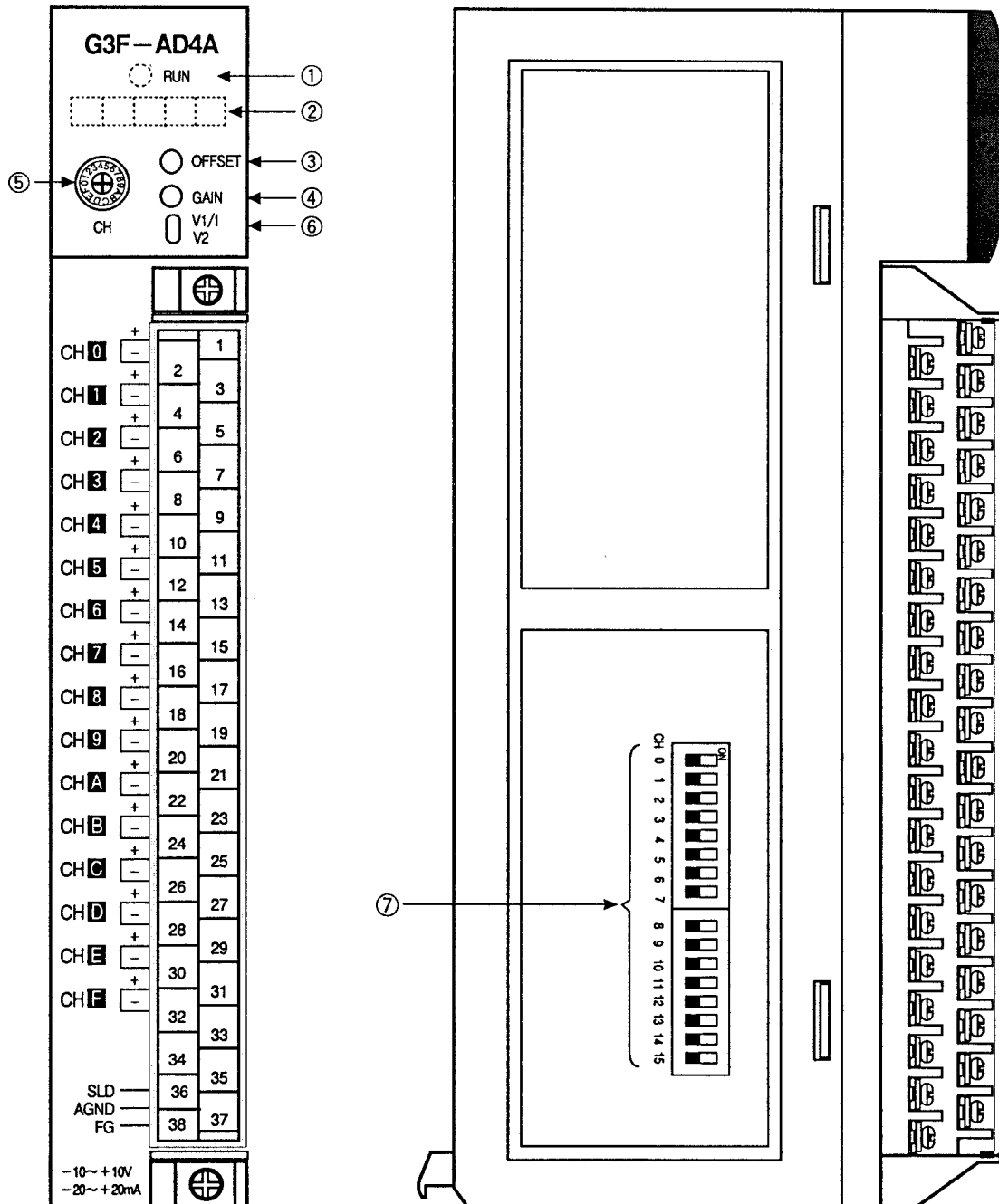

2.3 Names of Parts and Functions

The names of parts and functions of the A/D conversion module are shown as below.

2.3.1 G3F-AD4A

The names of parts and functions of the A/D conversion module are shown



No	Descriptions					
①	<p>RUN LED</p> <p>Indicates the operating status of the G3F-AD4A</p> <p>(1) On : Normal operation</p> <p>(2) Flicker : An error has occurred. (For more information, see the General Section 4.1)</p> <p>(3) Off : DC 5 V power-off or G3F-AD4A module fault.</p>					
②	<p>LED Display</p> <p>(1) Digital value indication</p> <ul style="list-style-type: none"> - Indicates a digital value of the channel specified by the channel switch. - Indicates a digital value as a 5-digit decimal (Display range: -8192 to 8181 or -192 to 16191) - Updates a digital value in 0.6sec <p>(2) Error number indication</p> <div style="display: flex; align-items: center;"> <table border="1" style="border-collapse: collapse; text-align: center; width: 100px;"> <tr> <td style="width: 20px;">E</td> <td style="width: 20px;">r</td> <td style="width: 20px;">r</td> <td style="width: 20px;"> </td> <td style="width: 20px;"> </td> </tr> </table> <div style="margin-left: 10px;"> <p>The one least significant digit indicates error code.</p>  </div> </div> <p>(3) Stop indication</p> <ul style="list-style-type: none"> - Indicates no channel specified by the channel switch. 	E	r	r		
E	r	r				
③	<p>Offset Trimmer</p> <p>Used to make micro adjustment of an offset value.</p>					
④	<p>Gain Trimmer</p> <p>Used to make micro adjustment of a gain value.</p>					
⑤	<p>Channel switch</p> <ul style="list-style-type: none"> - Used to set the channel of which digital value is displayed. - Setting range : 0 to F 					
⑥	<p>Input range switch</p> <p>- On factory set, the voltage range has to be set to from -10 to 10 VDC.</p> <p>(1) Set to voltage</p> <div style="display: flex; justify-content: space-around; align-items: center;"> <div style="text-align: center;">  <p>↑ V1 : Voltage range -5 ~ 5 VDC</p> </div> <div style="text-align: center;">  <p>↓ V2 : Voltage range -10 ~ 10 VDC</p> </div> </div> <p>(2) Set to current</p> <div style="display: flex; justify-content: space-around; align-items: center;"> <div style="text-align: center;">  <p>↑ I : Current range -20 ~ 20 mA</p> </div> <div style="text-align: center;">  <p>↓ : Unusable</p> </div> </div>					
⑦	<p>Input select switch</p> <p>(1) Used to select the analog input(voltage or current input) of each channel</p> <ul style="list-style-type: none"> -Set to OFF to use voltage input. -Set to ON to uses current input. <p>(2) On factory set, it has to be set to voltage input condition. (Every Dip Switch is off.)</p> <div style="text-align: center;">  <p>CH 0 1 2 3 4 5 6 7 8 9 10 11 12 13 14 15</p> </div>					

2.3.2 G4F-AD2A

This section shows the names of parts and functions of G4F-AD2A module.

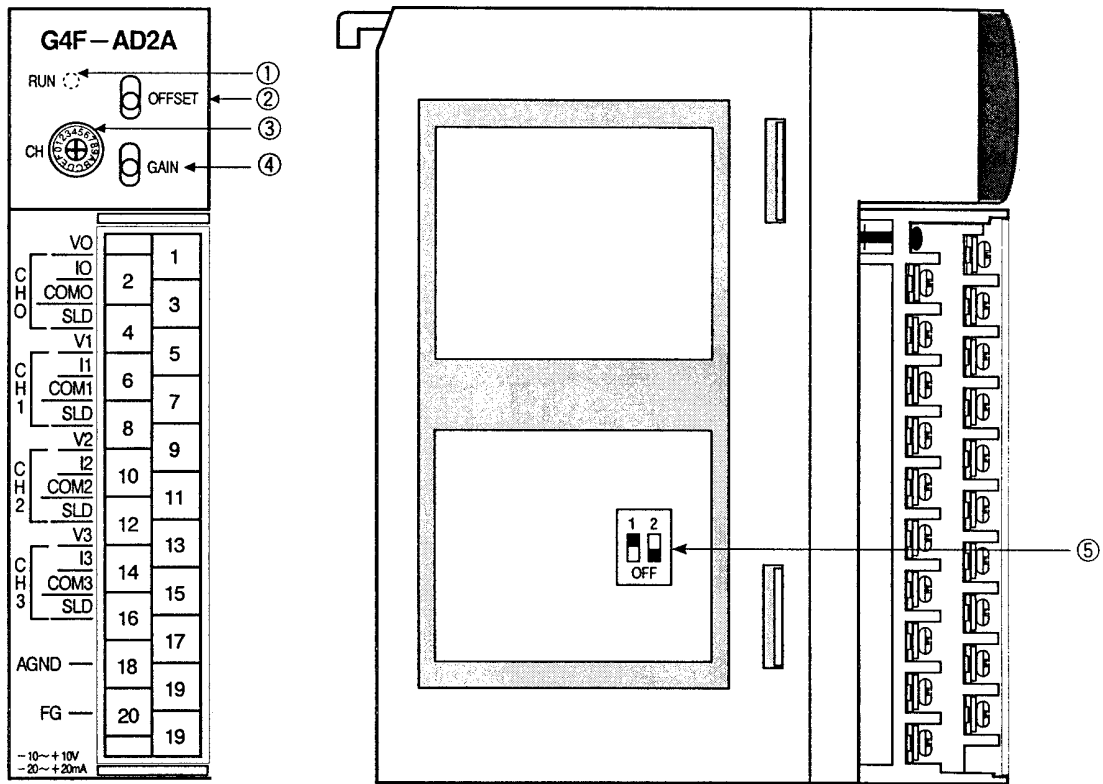

No	Descriptions	No	Descriptions											
①	<p>RUN LED</p> <p>Indicates the operating status of the G4F-AD2A.</p> <p>Normal mode: channel switch's setting range: 4 to F</p> <ul style="list-style-type: none"> - ON : Normal operation. - Flicker : An error has occurred. - OFF : DC5V power-off or G3F-AD4A module fault. <p>Test mode: channel switch's range: 0 to 3</p> <ul style="list-style-type: none"> - Flicker(per 1.0sec) : No operation of offset/gain switch. - ON : Offset/gain switch adjusted upward. - Flicker(per 0.2sec) : offset/gain setting error. 	④	<p>GAIN switch</p> <p>Adjust upward, and the analog input value of corresponding channels is stored as a gain value.</p>											
②	<p>Offset switch</p> <p>Adjust upward, and the analog input value of corresponding channels is stored as an offset value.</p>	⑤	<p>Input range select switch</p> <table border="1" style="width: 100%; border-collapse: collapse;"> <thead> <tr> <th></th> <th>Analog input</th> <th>Switch</th> </tr> </thead> <tbody> <tr> <td rowspan="2">Voltage</td> <td>-10 ~ 10 VDC</td> <td></td> </tr> <tr> <td>-5 ~ 5 VDC</td> <td></td> </tr> <tr> <td>Current</td> <td>-20 ~ 20 mA</td> <td></td> </tr> </tbody> </table> <p>* Don't put the input switch on or . * It leads to malfunction.</p>		Analog input	Switch	Voltage	-10 ~ 10 VDC		-5 ~ 5 VDC		Current	-20 ~ 20 mA	
	Analog input	Switch												
Voltage	-10 ~ 10 VDC													
	-5 ~ 5 VDC													
Current	-20 ~ 20 mA													
③	<p>Channel switch for the test mode</p> <p>Corresponding channels will be selected in the adjustment of offset/gain value. (Valid range: 0 to 3)</p>													

2.4 I/O Conversion Characteristics

Input / Output (hereafter I/O) conversion characteristics are expressed by the angle of the line connecting the offset value and gain value used to convert the analog signals, input to the PLC into digital values.
 The I/O conversion characteristics of the A/D conversion module are shown as below.

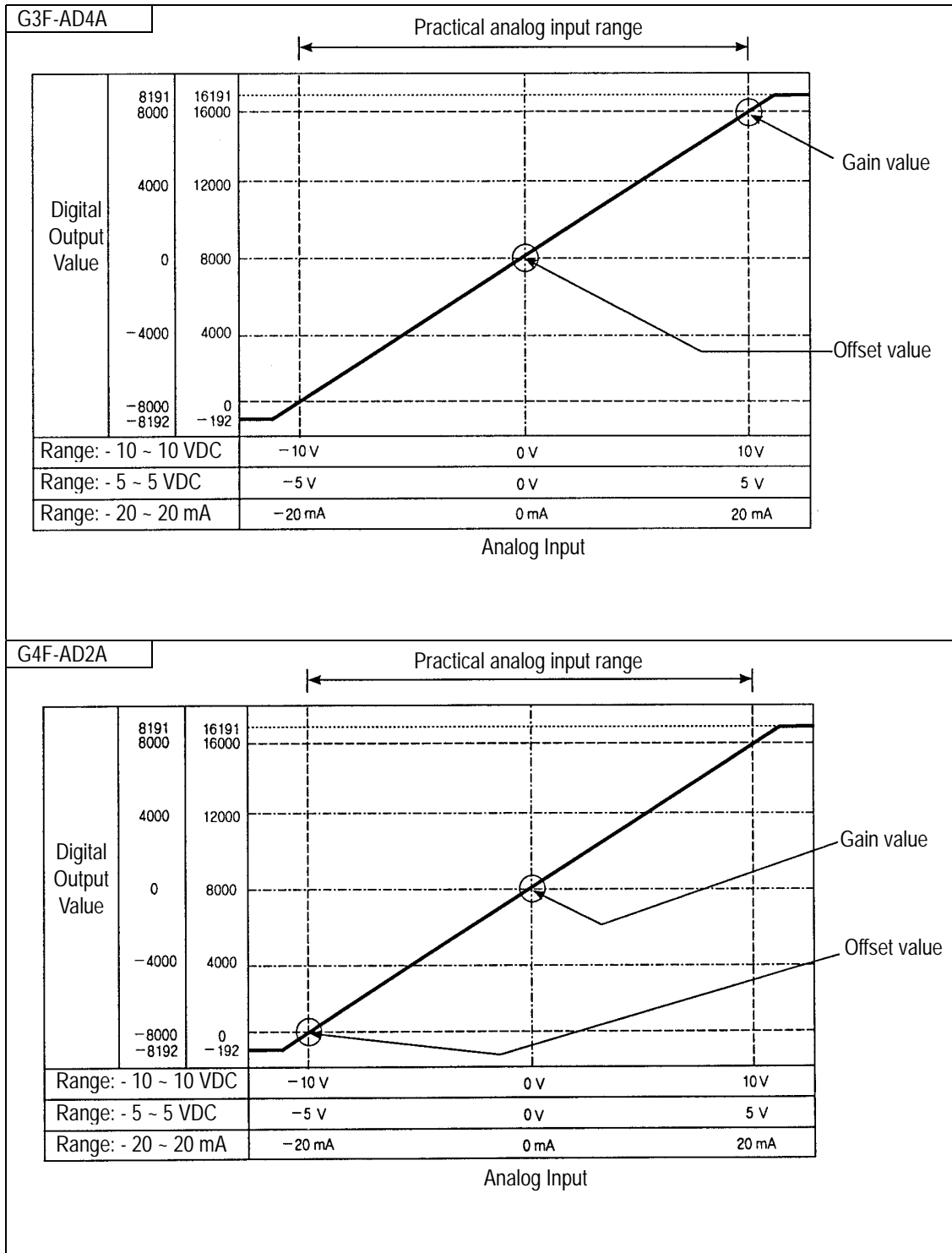

[Fig 2.1] I/O Conversion Characteristics

2.4.1 G3F-AD4A I/O Characteristics

The G3F-AD4A allows voltage or current input to be selected per channel by the input select switch. Offset / gain setting is performed for 16 channels in block.

1) Voltage Input Characteristics

For voltage input, the input select switch of each channel is set to "off".

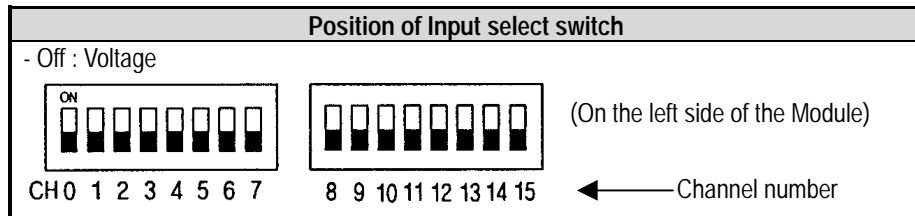

a) Range : -10 ~ 10 VDC

-The analog input range switch has to be set to downward (V2).

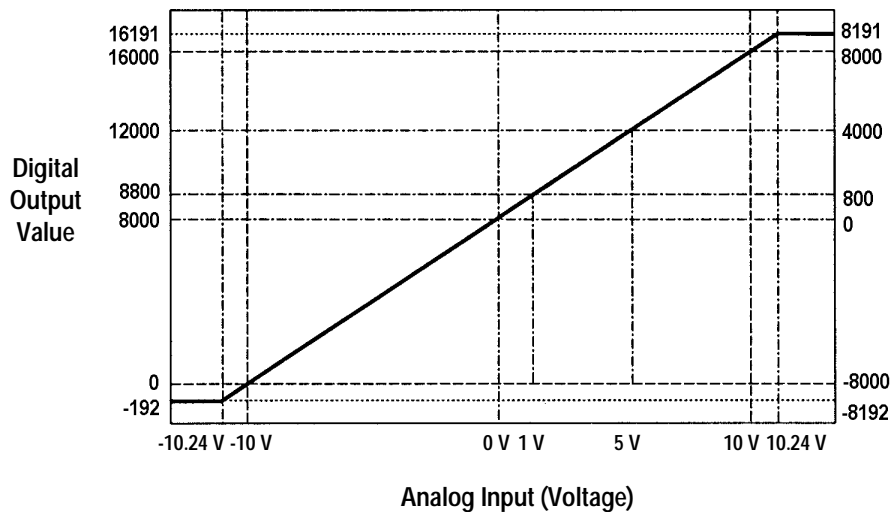
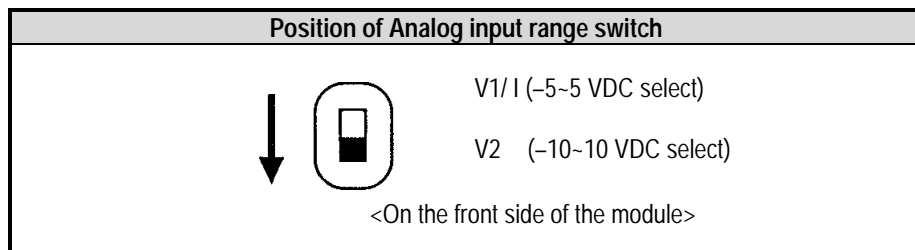

-The digital output value according to voltage input characteristics will be shown as below.

Digital output range	Analog input voltage				
	-10 V	0 V	1 V	5 V	10 V
-192~16191	0	8000	8800	12000	16000
-8192~8191	-8000	0	800	4000	8000

b) Range: -5 ~ 5 VDC

-The analog input range switch has to be set upward (V1/ I)

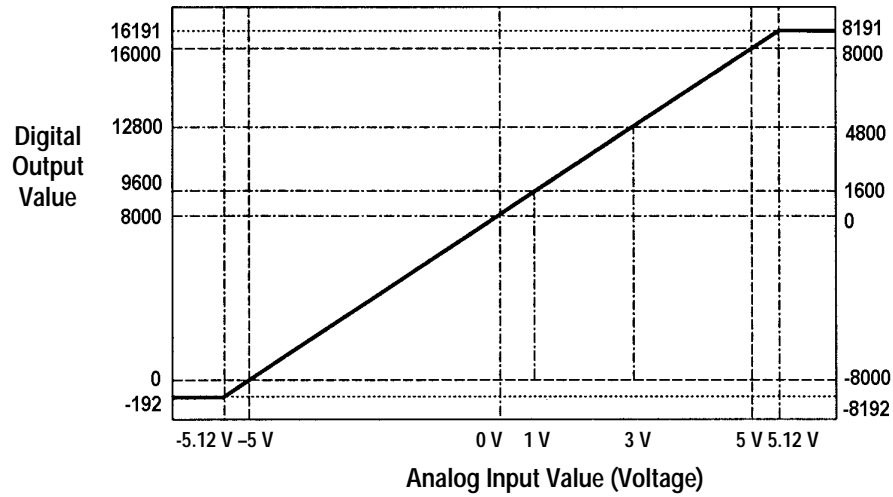
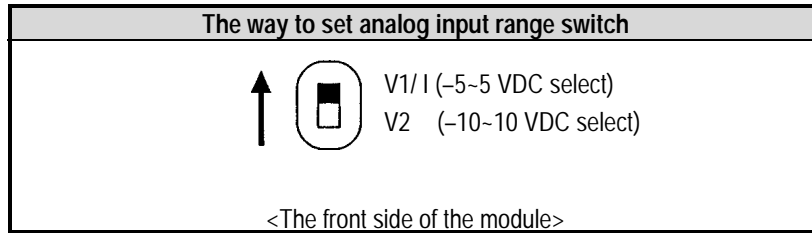

-The digital output value according to voltage input characteristics will be shown as below.

Digital output range	Analog input voltage				
	-5 V	0 V	1 V	3 V	5 V
-192~16191	0	8000	9600	12800	16000
-8192~8191	-8000	0	1600	4800	8000

2) Current Input Characteristics

- For current input, the input select switch of each channel is set to "on".

Analog input range switch has to be set upward (V1/ I).

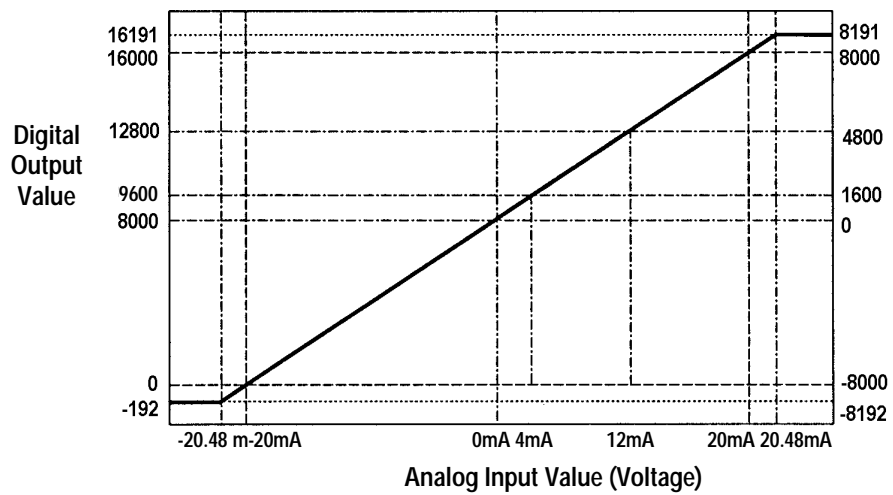
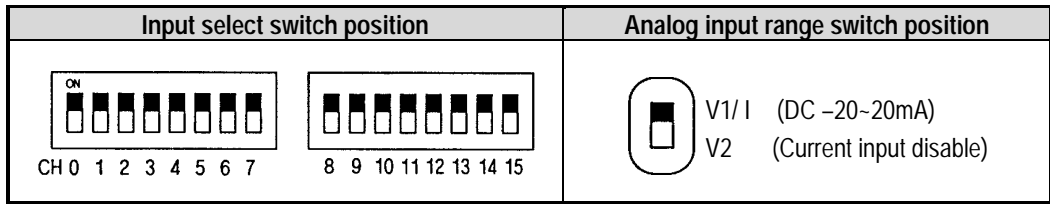

- The digital output value according to current input characteristics will be shown as below.

Digital output range	Analog input current				
	-20 mA	0 mA	4 mA	12 mA	20 mA
-192~16191	0	8000	9600	12800	16000
-8192~8191	-8000	0	1600	4800	8000

3) Simultaneous Voltage and Current Input Characteristics

For simultaneous voltage and current input, the input conversion switch of each channel is set to corresponding voltage and current range.

Analog input switch has to be set upward (V1/ I).

Ex) Voltage input range: 0 to 7 Current input range: 8 to 15

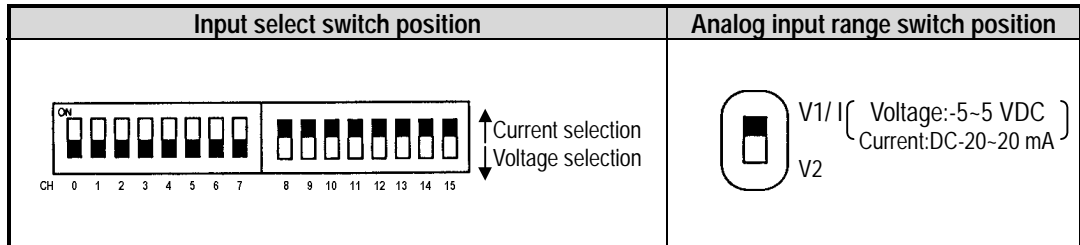

- For simultaneous voltage and current input, voltage input range has to be set only to the range [-5 ~ 5 VDC].

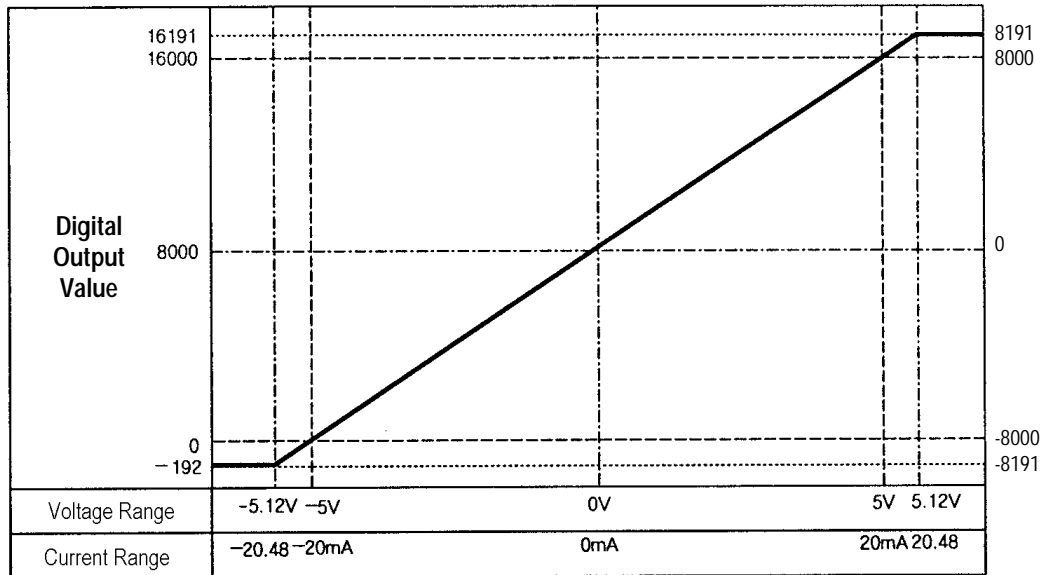

Analog Input

- Simultaneous voltage and current input characteristics lead to digital output value as below.

Digital output range	Analog input				
	-5 V	0 V	1 V	3 V	5 V
	-20 mA	0 mA	4 mA	12 mA	20 mA
-192~16191	0	8000	9600	12800	16000
-8192~8191	-8000	0	1600	4800	8000

2.4.2 G4F-AD2A I/O Characteristics

1) Voltage Input Characteristics

- The G4F-AD2A is capable of selecting voltage/current and adjusting offset/gain for each channel.
- For voltage input, the input conversion switch may be set to the range such as from -10 to 10 VDC, or from -5 to 5 VDC.

a) -10 ~ 10 VDC

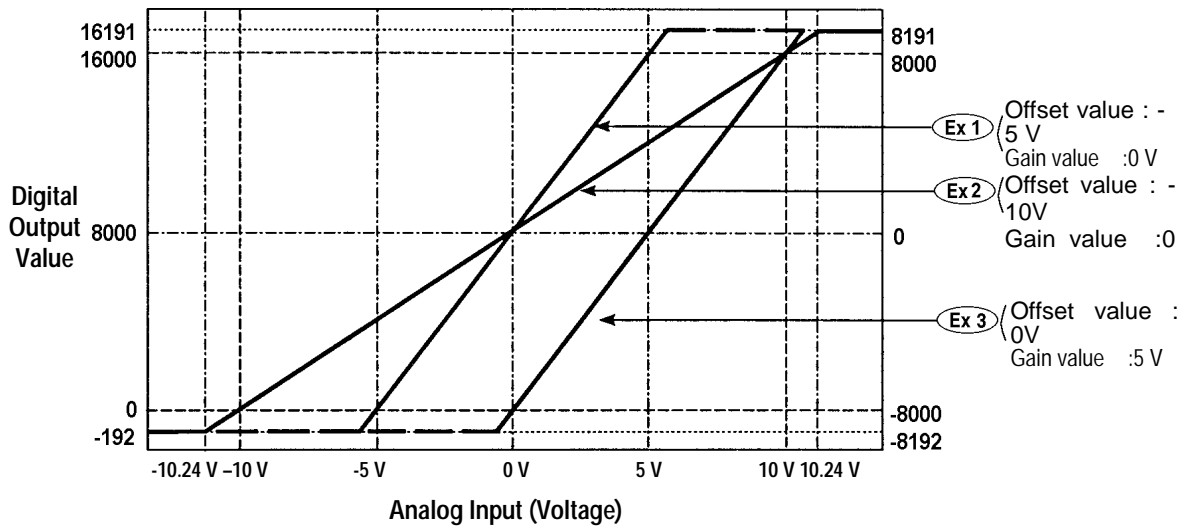
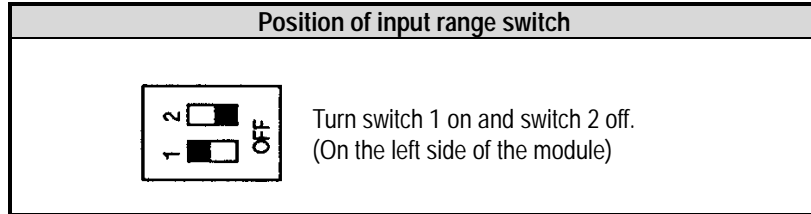

- When offset/gain setting is changed, digital output value to voltage input characteristics are as below.

Section	Digital output range	Offset value	Gain value	Analog input voltage					
				- 10 V	- 5 V	0 V	3 V	5 V	10 V
Ex 1	-192 ~ 16191	-5 V	0 V	-192	0	8000	12800	16000	16191
Ex 2		-10 V	0 V	0	4000	8000	10400	12000	16000
Ex 3		0 V	5 V	-192	-192	0	4800	8000	16000
Ex 1	-8192 ~ 8191	-5 V	0 V	-8192	-8000	0	4800	8000	8191
Ex 2		-10 V	0 V	0	-4000	0	2400	4000	8000
Ex 3		0 V	5 V	-8192	-8192	-8000	-3200	0	8000

b) -5 ~ 5 VDC

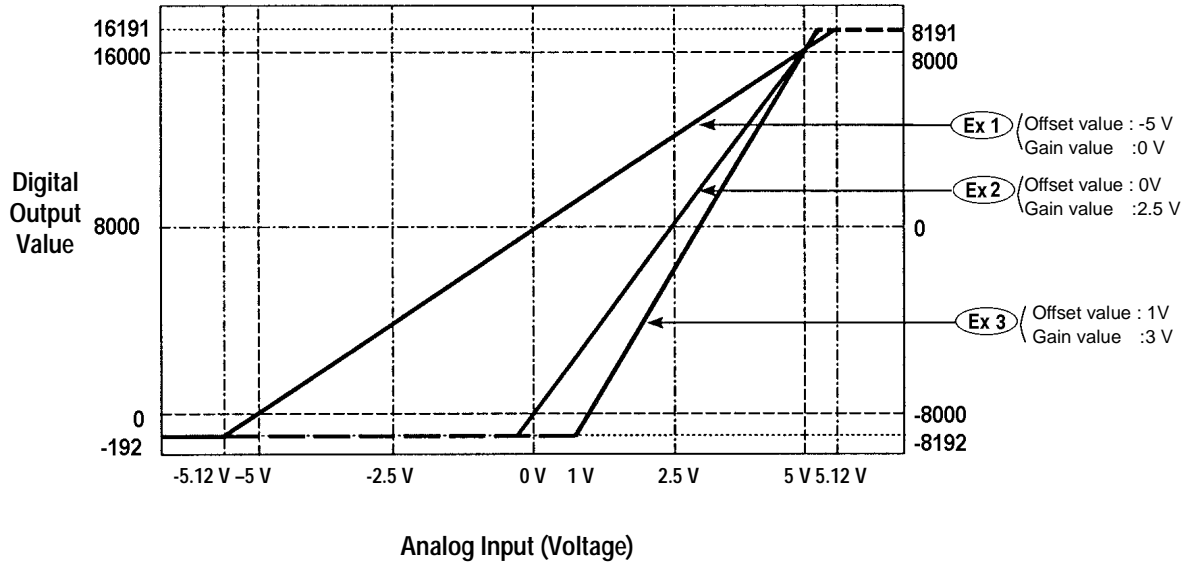
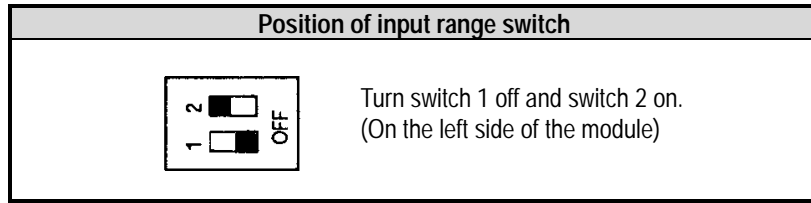

- When offset/gain setting is changed, digital output value to voltage input characteristics are shown as below.

Section	Digital output range	Offset value	Gain value	Analog input voltage				
				- 5 V	0 V	1 V	3 V	5 V
Ex 1	-192 ~ 16191	-5 V	0 V	0	8000	9600	12800	16000
Ex 2		0 V	2.5 V	-192	0	3200	9600	16000
Ex 3		1 V	3 V	-192	-192	0	8000	16000
Ex 1	-8192 ~ 8191	-5 V	0 V	-8000	0	1600	4800	8000
Ex 2		0 V	2.5 V	-8192	-8000	-4800	1600	8000
Ex 3		1 V	3 V	-8192	-8192	-8000	0	8000

2) Current Input Characteristics

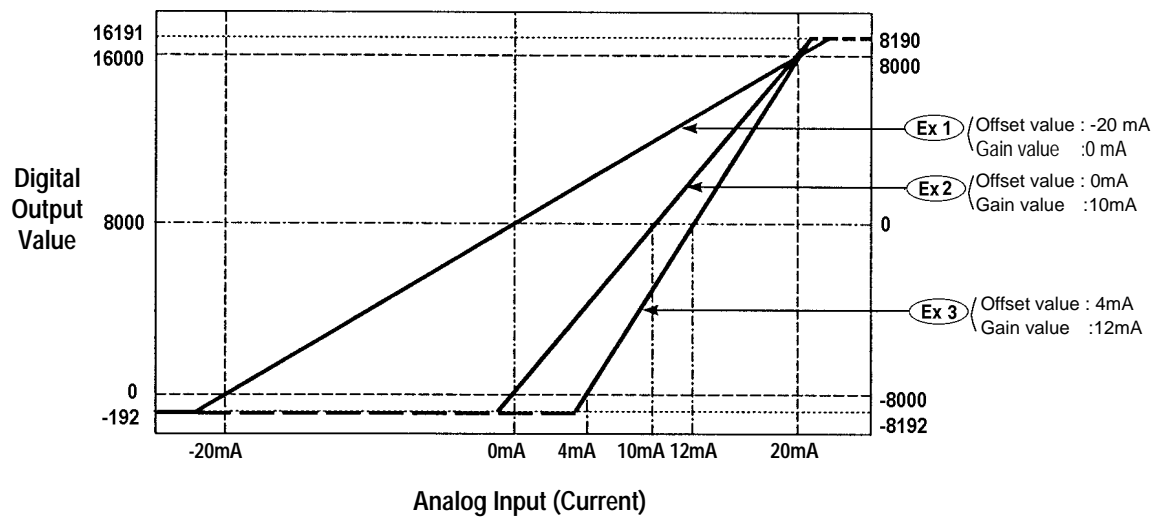

- When offset/gain setting is changed, digital output value to current input characteristics are shown as below.

Section	Digital output range	Offset value	Gain value	Analog input current					
				- 20 mA	0 mA	4 mA	10 mA	12 mA	20 mA
Ex 1	-192 ~ 16191	-20 mA	0 mA	0	8000	9600	12000	12800	16000
Ex 2		0 mA	10 mA	-192	0	3200	8000	9600	16000
Ex 3		4 mA	12 mA	-192	-192	0	6000	8000	16000
Ex 1	-8192 ~ 8191	-20 mA	0 mA	-8000	0	1600	4000	4800	8000
Ex 2		0 mA	10 mA	-8192	-8000	-4800	0	1600	8000
Ex 3		4 mA	12 mA	-8192	-8192	-8000	-2000	0	8000

3) Simultaneous Voltage and Current Input Characteristics

-When voltage and current are input simultaneously, the input range switch of the left side of the module has to be set to the range of from -5 to 5 VDC. (Switch 1 turns Off, Switch 2 turns On)

Ex) Voltage input channel : 0, Current input channel : 1

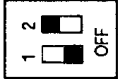
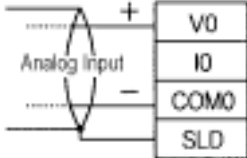
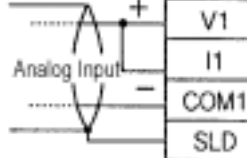
Input range select switch (on the left side of module)	Terminal connection	
	voltage input (channel 0)	current input (channel 1)
 -5 ~ 5 VDC -10 ~ 10 VDC		

-When voltage and current are input simultaneously, voltage input range has to be set only to the range from -5 to 5 VDC.

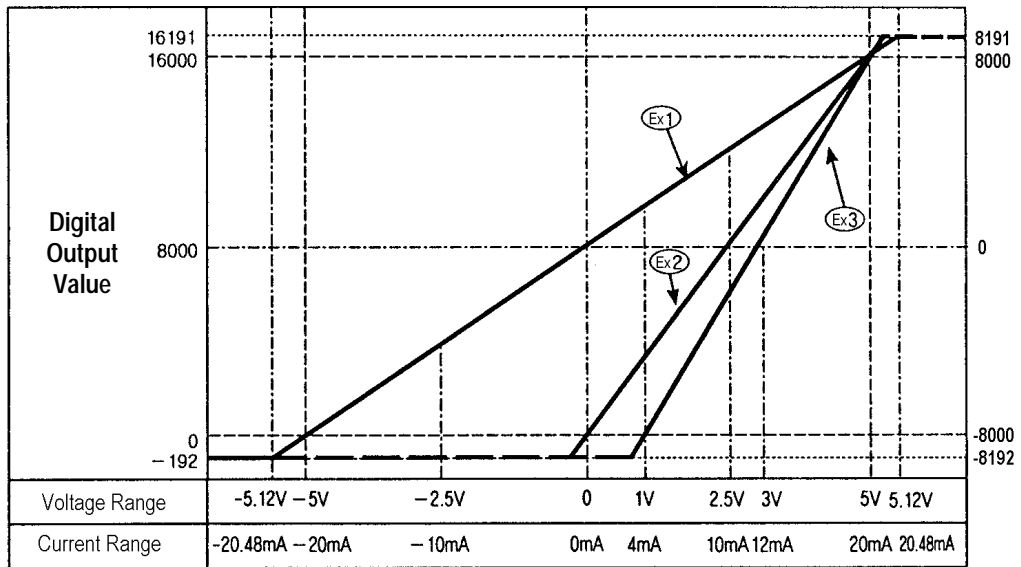

Analog Input

-When offset/gain setting is changed, digital output value to voltage/current input characteristics are shown as below.

Section	Digital output range	Offset value (Voltage / Current)	Gain value (Voltage / Current)	Analog input					
				-5 V	0 V	1 V	2.5 V	3 V	5 V
				-20 mA	0 mA	4 mA	10 mA	12 mA	20 mA
Ex 1	-192 ~ 16191	-5 V / -20 mA	0 V / 0 mA	0	8000	9600	12000	12800	16000
Ex 2		0 V / 0 mA	2.5 V / 10 mA	-192	0	3200	8000	9600	16000
Ex 3		1V / 4 mA	3 V / 12 mA	-192	-192	0	6000	8000	16000
Ex 1	-8192 ~ 8191	-5 V / -20 mA	0 V / 0 mA	-8000	0	1600	4000	4800	8000
Ex 2		0 V / 0 mA	2.5 V / 10 mA	-8192	-8000	-4800	0	1600	8000
Ex 3		1 V / 4 mA	3 V / 12 mA	-8192	-8192	-8000	-2000	0	8000

! Caution

- When digital output is set to the range of -192 to 16191, despite a analog input more than the range of -192 to 16191, Digital output value is set to -192 or 16191.
When digital output is set to the range of -8192 to 8191, despite a analog input more than the range of -8192 or 8191, digital output value is set to -8192 or 8191.
- Do not apply $\pm 15\text{ V} / \pm 25\text{ mA}$ or more. This will damage the module due to a heat rise.
- Set an offset/gain value on the G4F-AD2A to the range that gain value is more than offset value, or you won't get an accurate digital output.

2.4.3 Relations between Offset/gain Setting and Digital Output Value

1) Resolution

Resolution is determined as below formulas.

(1) Voltage input

$$\text{Resolution} = \frac{\text{Gain value} - \text{Offset value}}{8000} \times 1000 \text{ (mV)}$$

Ex) Gain value : 0 V Offset value : - 10 V

$$\text{Resolution} = \frac{0 - (-10)}{8000} \times 1000 \text{ mV} = 1.25 \text{ mV}$$

(2) Current input

$$\text{Resolution} = \frac{\text{Gain value} - \text{Offset value}}{8000} \times 1000 \text{ (}\mu\text{A)}$$

Ex) Gain value : 0 mA Offset value : - 20 mA

$$\text{Resolution} = \frac{0 - (-20)}{8000} \times 1000 \mu\text{A} = 2.5 \mu\text{A}$$

2) Relations between Maximum Resolution and Digital Output Value

On the occasion of calculating, as follows, by offset/gain setting, digital output value 1 at a time doesn't increase or decrease.

$$\frac{\text{Gain value} - \text{Offset value}}{8000} < \text{Resolution}$$

3) Offset / Gain Setting

(1) Offset/gain setting of the G3F-AD4A

a) Offset/gain sets procedure.

: Offset/gain setting is performed for 16 channels in block.

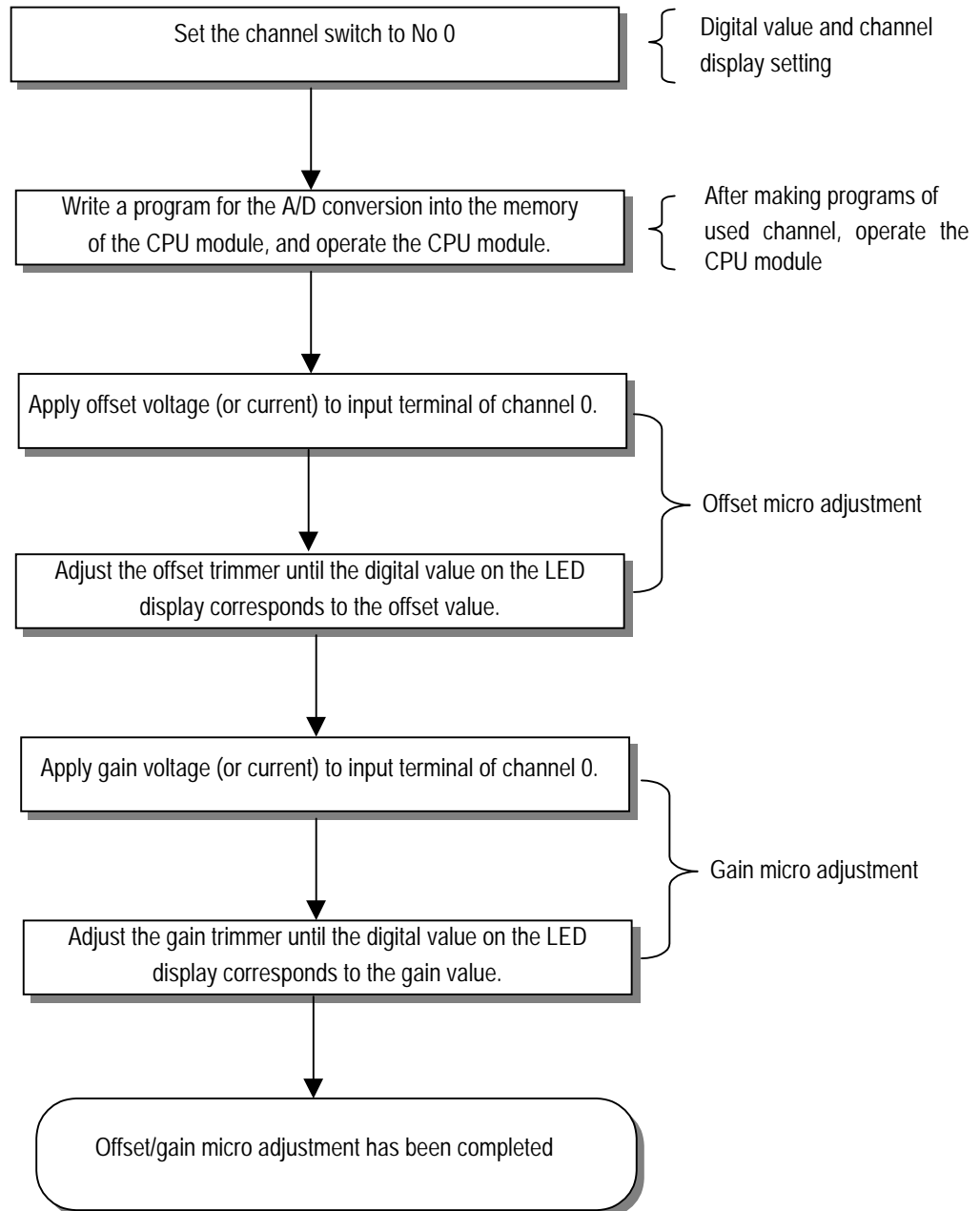

b) I/O characteristics in accordance with offset/gain setting

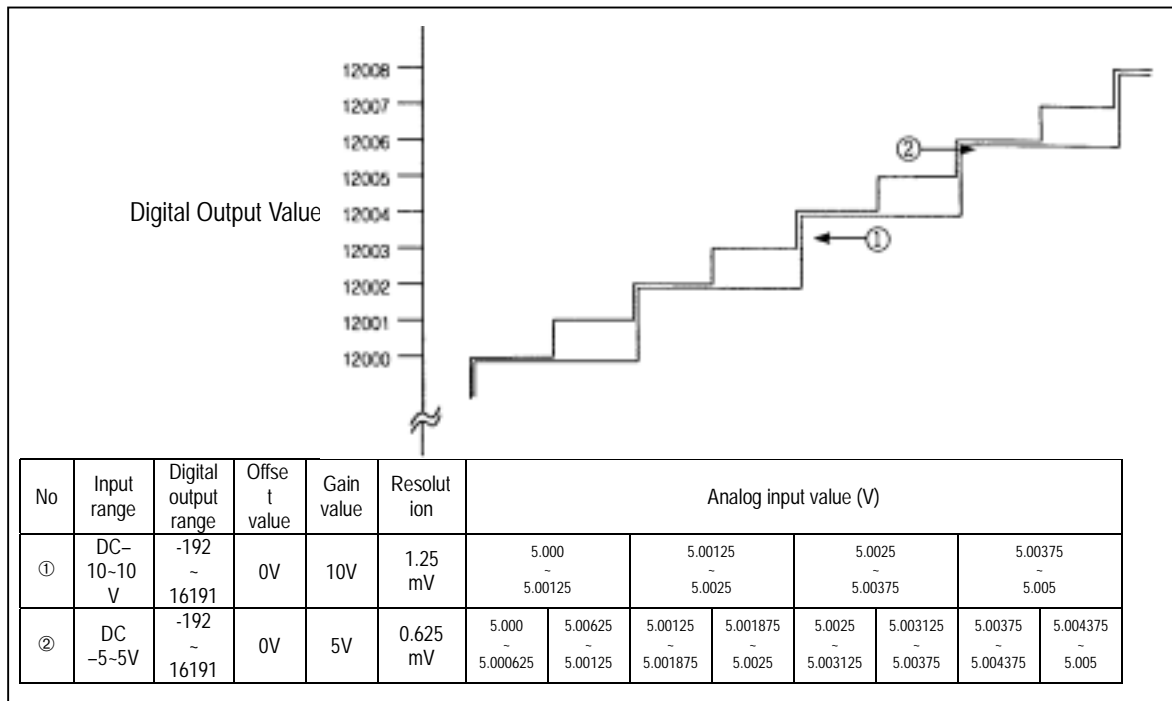

Voltage input and digital output value

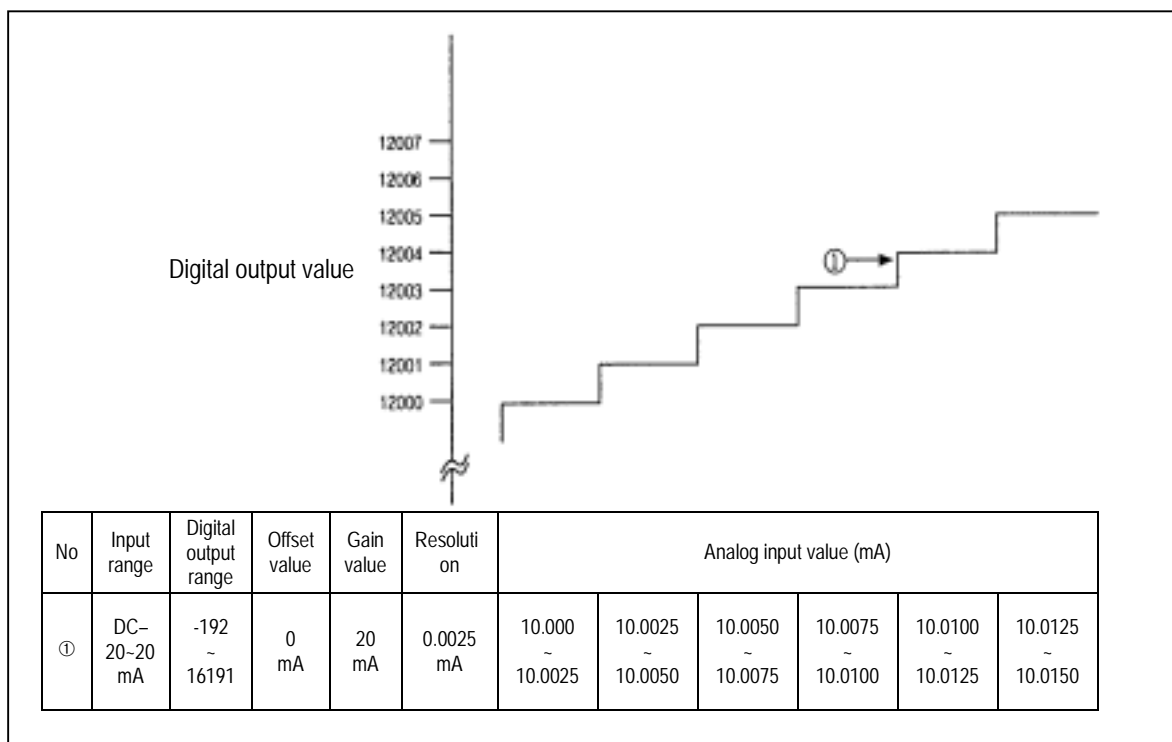

Current input and digital output value

(2) Offset/gain Setting of the G4F-AD2A

a) Offset/gain Setting Procedure

Set offset / gain values for each channel.

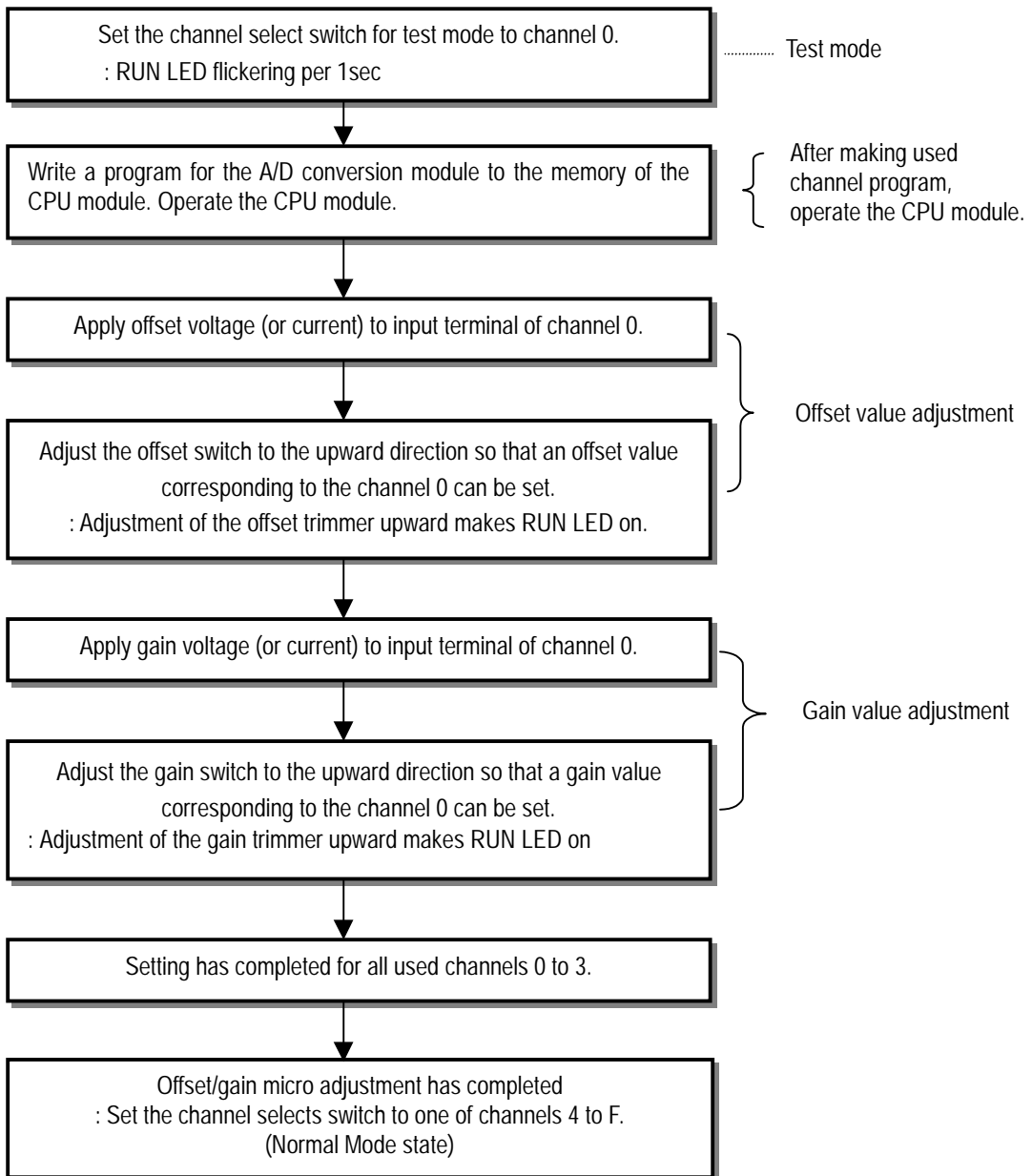

REMARK

- (1) Set offset/gain value within practical input range.
- (2) Offset/gain value is stored in the G4F-AD2A and remains after power-off.
- (3) Set offset/gain value to the range of from -10 to 10 volts DC or from -20 to 20 mA.
However, if this range is exceeded, the resolution and accuracy will be impaired.
- (4) At the change of grounding position in the *5 of 3.2.2, be sure to restart offset/gain value from the beginning

b) Input/output Characteristics According to Offset/gain Setting

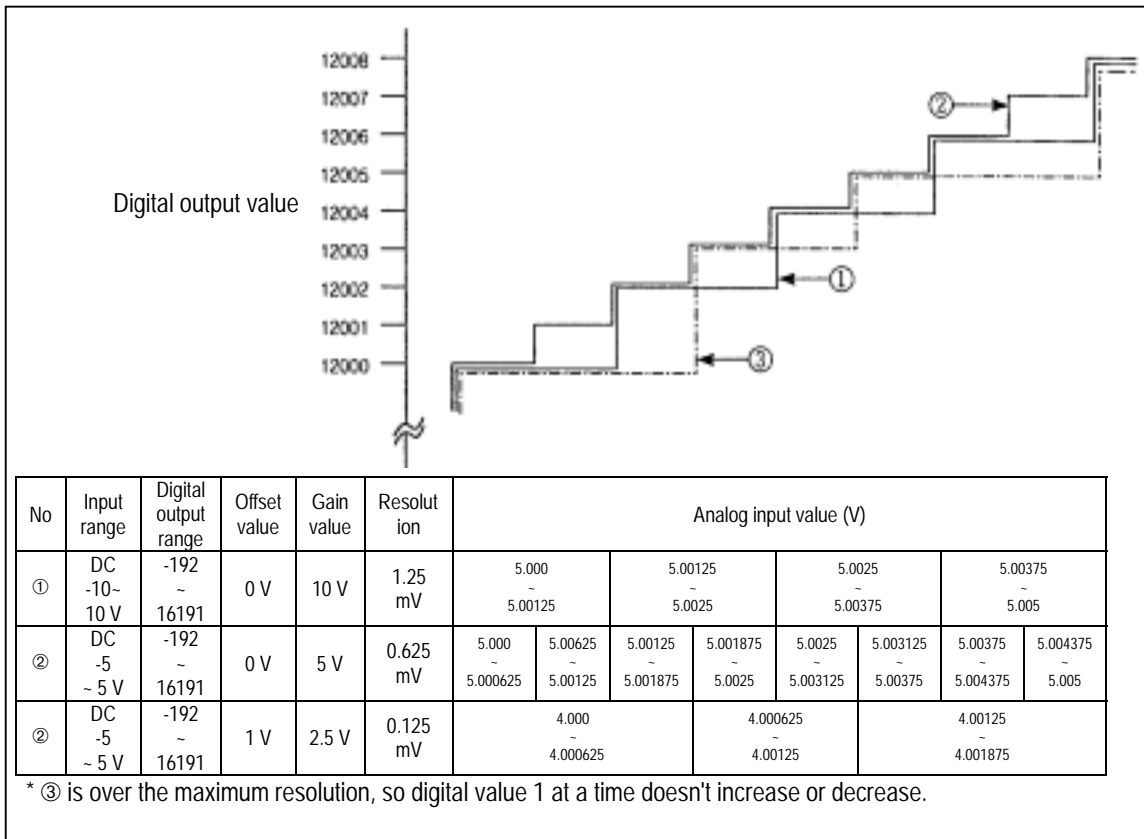

Voltage input and digital output value

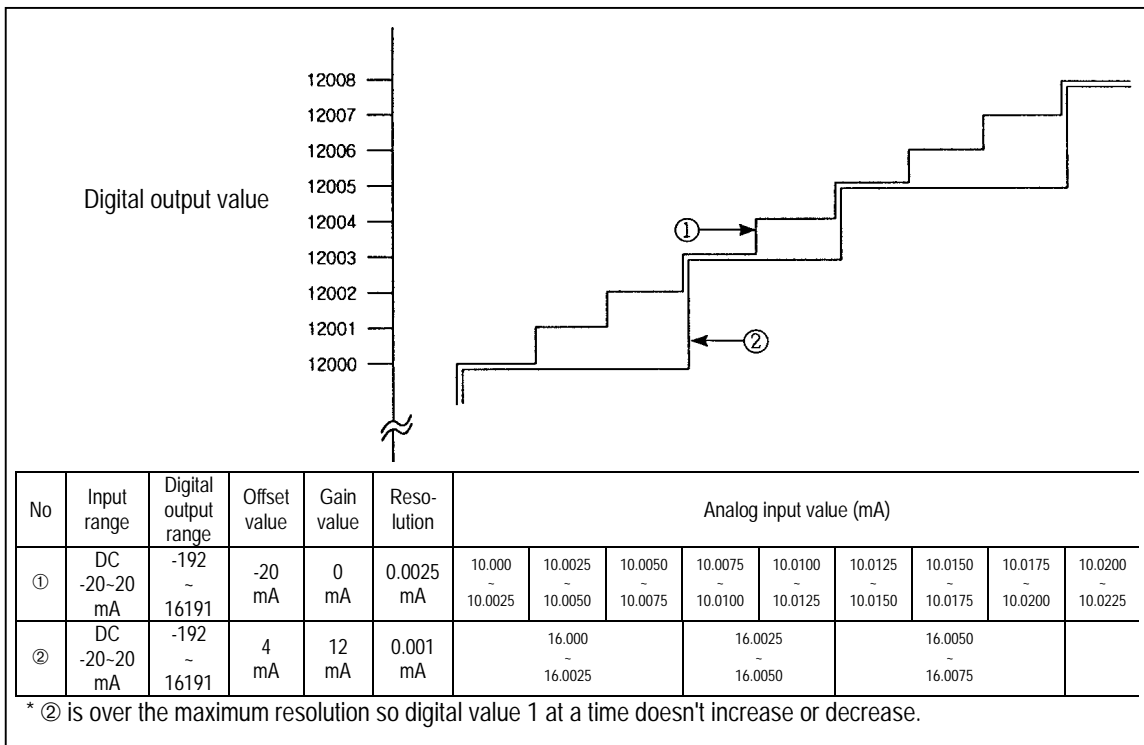

Current input and digital output value

2.5 A/D Conversion Characteristics

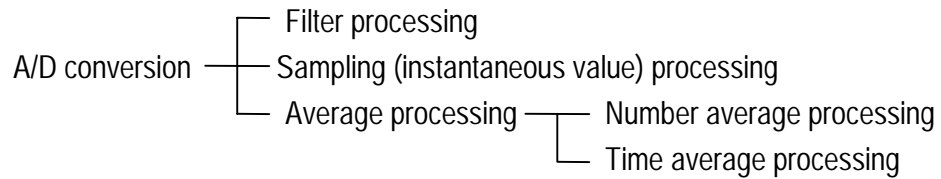

2.5.1 Filter Processing

Filter processing noise or the quick change of input value helps to use a stable digital value compared with analog value.

$$PVfn = (1 - \alpha) \times PVn + \alpha PVfn - 1$$

- PVfn : present filter output value
- PVn : present A/D conversion value
- PVfn-1 : previous filter output value
- α : Filter constant(the range: 0.01 to 0.99)
Filter constants used here are 1 to 99.

Ex) When analog value is changed in the sequence like -10V, -5V, 0V, and 5V, filter output is shown as below.

Value of α	Filter output value			Remarks	
0.01	0	3960	7960	11960	α leaning to the previous value by 1 %
0.5	0	2000	5000	8500	α leaning to the previous value by 50 %
0.99	0	40	120	239	α leaning to the previous value by 99 %

That is, filter disable allows present A/D conversion value to be displayed and filter enable allows A/D conversion value to be displayed by filter constant according to the relative importance between present A/D conversion value and previous.

2.5.2 Sampling Processing (Instantaneous Value)

This is general A/D conversion processing. In other words, analog input value has to be converted to digital value even without average processing. Sampling period for writing digital value to the memory is changed according to the number of used channels.

$$\text{(Process time)} = \text{(Number of channels)} \times \text{Conversion speed}$$

Ex) When 3 channels are used.

- G3F – AD4A : $3 \times 3(\text{Conversion speed}) = 9 \text{ (ms)}$
- G4F – AD2A : $3 \times 5(\text{Conversion speed}) = 15 \text{ (ms)}$

Sampling processing means, when average processing isn't used, analog input value is to be converted to digital value in direct.

2.5.3 Average Processing

1) The Cause of Average Processing

Average processing of noise or abnormal analog input is used to stabilize system control.

2) Kinds of Average Processing

There are kinds of average processing, which are time average and number average.

(1) Time Average Processing

a) Setting Range

G3F-AD4A : 96 to 12,000 (ms)

G4F-AD2A : 40 to 20,000(ms)

b) On the time average processing, the number of average processing within the Set time is determined according to the number of channels.

$$\text{Processing number} = \frac{\text{Set time}}{\text{Used channels} \times \text{Conversion speed}}$$

Ex) Used channels : 4, Set time : 120 ms

G3F-AD4A : $120 \div (4 \times 3) = 10$ count

G4F-AD2A : $120 \div (4 \times 5) = 6$ count

c) When Set time divided by (Number of used channel \times Conversion speed) makes the residue occur, the processing number will be [{ average processing number \div (the number of used channel \times conversion speed) } + 1] by raising the residue.

Ex) Used channels: 4, Set time : 200 ms

G3F-AD4A : $150 \div (4 \times 3) = 12$ count + remain 6 \rightarrow 13 count

G4F-AD2A : $150 \div (4 \times 5) = 7$ count + remain 10 \rightarrow 13 count

(2) Number Average Processing

a) Setting range

G3F - AD4A : 2 to 4000 (count)

G4F - AD2A : 2 to 4000 (count)

b) Number average processing period for writing digital value to the buffer memory is changed according to the number of channels.

$$\text{Processing time} = \text{Setting times} \times \text{Number of enabled channels} \times \text{Conversion speed}$$

Ex) Used channels: 4, Average processing time: 50 count.

G3F - AD4A : $50 \times 4 \times 3 = 600$ ms

G4F - AD2A : $50 \times 4 \times 5 = 1000$ ms

Chapter 3. INSTALLATION AND WIRING

3.1 Installation

3.1.1 Installation Ambience

This module has high reliability regardless of its installation ambience. But be sure to check the following for system in higher reliability and stability.

1) Ambience Requirements

Avoid installing this module in locations, which are subjected or exposed to:

- Water leakage and dust a large amount of dust, powder and other conductive power, oil mist, salt, of organic solvent exists.
- Mechanical vibrations of impacts are transmitted directly to the module body.
- Direct sunlight.
- Dew condensation due to sudden temperature change.
- High or low temperatures (outside the range of 0-55 °C)

2) Installing and Wiring

- During wiring or other work, do not allow any wire scraps to enter into it.
- Install it on locations that are convenient for operation.
- Make sure that it is not located near high voltage equipment on the same panel.
- Make sure that the distance from the walls of duct and external equipment be 50 mm or more.
- Be sure to be grounded to locations that have good noise immunity.

3.1.2 Handling Precautions

From unpacking to installation, be sure to check the following:

- 1) Do not drop it off, and make sure that strong impacts should not be applied.
- 2) Do not dismount printed circuit boards from the case. It can cause malfunctions.
- 3) During wiring, be sure to check any foreign matter like wire scraps should not enter into the upper side of the PLC, and in the event that foreign matter entered into it, always eliminate it.
- 4) Be sure to disconnect electrical power before mounting or dismounting the module.

3.2 Wiring

3.2.1 Wiring Precautions

- 1) Separate AC and external input signal of A/D conversion module wiring not to be affected by surge or induced noise in the AC.
- 2) External wiring has to be at least AWG22(0.3mm²) and be selected in consideration of operating ambience and/or allowable current.
- 3) Separate wiring from devices and/or substances generating intense heat, and oil not to make short-circuit which leads to damage and/or mis-operation.
- 4) Identify the polarity of terminal block before external power supply is made connected.
- 5) Separate external wiring sufficiently from high voltage and power supply cable not to cause induced failure and/or malfunction.
- 6) Don't put the power cable in front of the LED display
(In order to read the digital value on the LED correctly)

3.2.2 Wiring Examples

1) G3F-AD4A

(1) Voltage Input

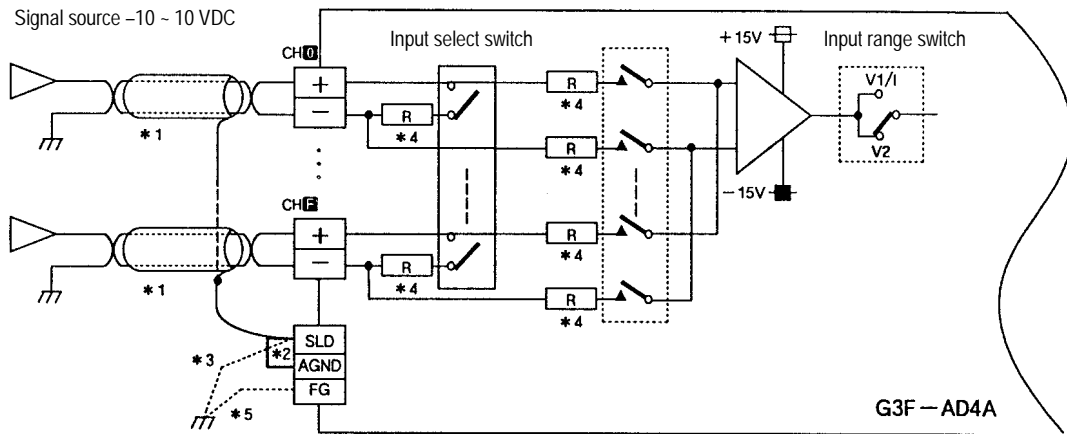

(2) Current Input

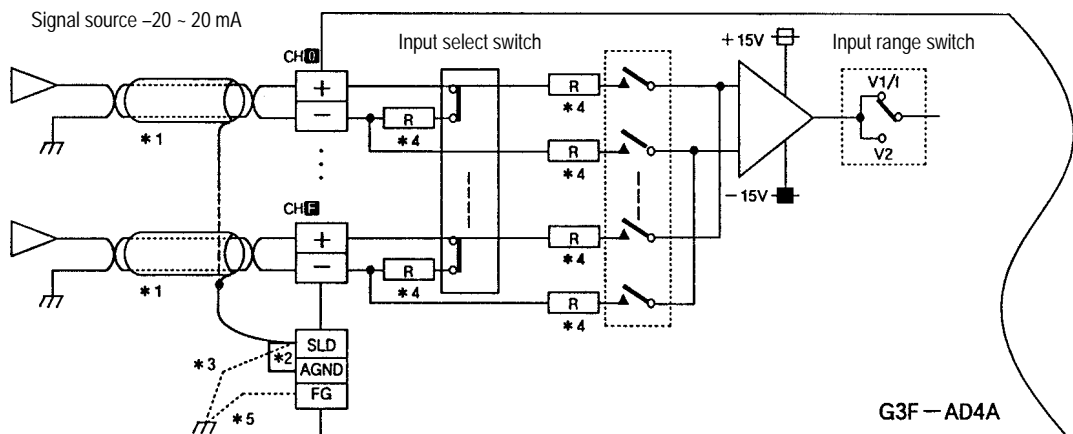

- *1 For the cable, use a two-core twisted shielded wire.
- *2 The SLD terminal and AGND terminal has to be connected.
- *3 When there is much noise, the SLD terminal and FG terminal has to be grounded.
- *4 Input resistance has been shown.
- *5 When there is much noise, FG of the power supply module must be grounded.

2) G4F-AD2A

(1) Voltage Input

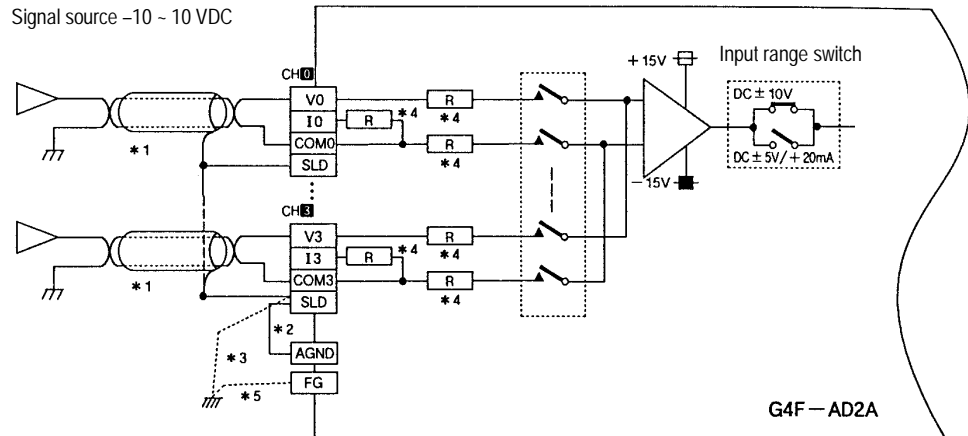

(2) Current Input

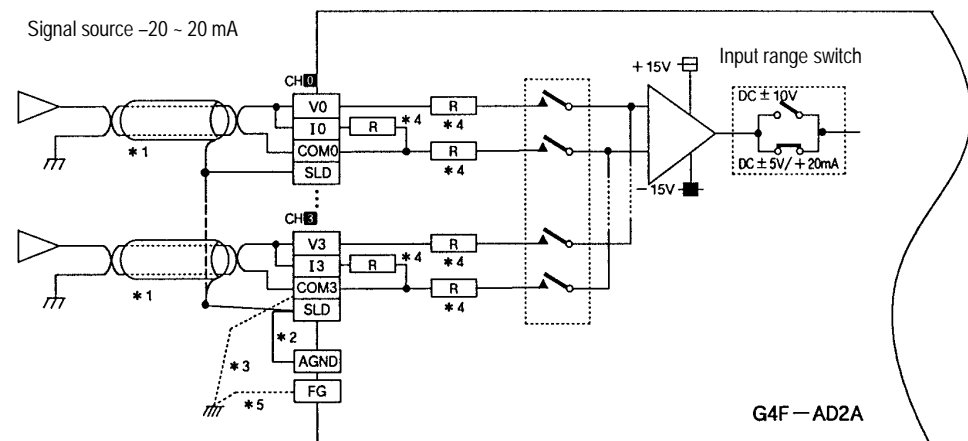

*1 For the cable, use a two-core twisted shielded wire.

*2 The SLD terminal and AGND terminal has to be connected.

*3 When there is much noise, the SLD terminal and FG terminal has to be grounded.

*4 Input resistance has been shown.

*5 When there is much noise, FG of the power supply module must be grounded.

Chapter 4. TROUBLESHOOTING

This section shows the descriptions of the error code and troubleshooting during use of the A/D conversion module.

4.1 Error Code

4.1.1 Error Code Indicated by RUN LED Flickering

Errors occurring during RUN LED flickering are shown as below.

RUN LED	Descriptions	LED display of the G3F-AD4A	Remarks
flicker(per 0.1sec)	WDT error	Err 1	
flicker(per 0.2sec)	System error	Err 0	
	Buffer memory error	Err 2	
	Offset / gain setting error	-	

4.2 Troubleshooting

4.2.1 RUN LED Flickering

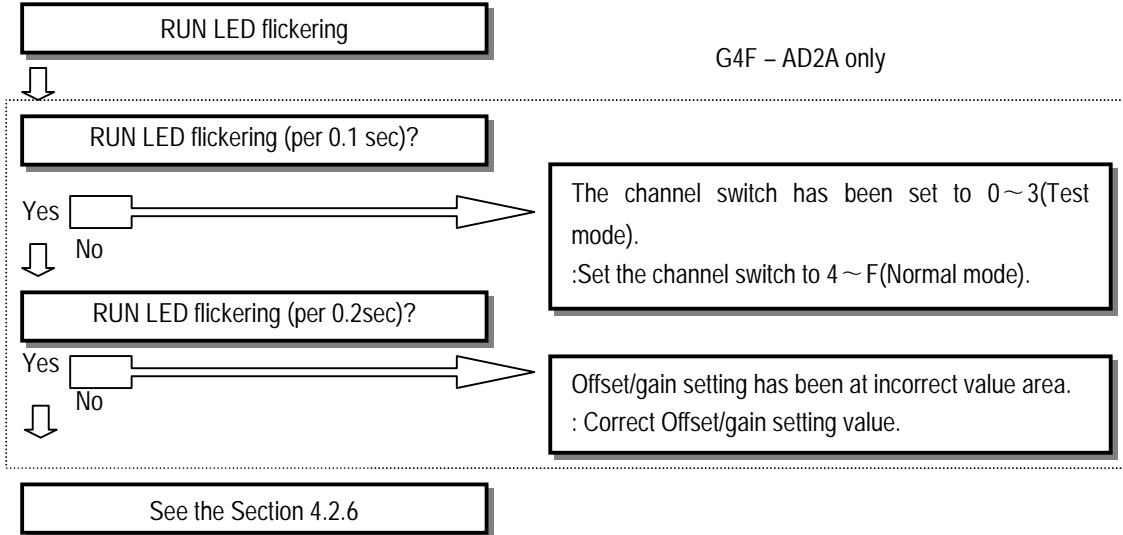

4.2.2 RUN LED Off

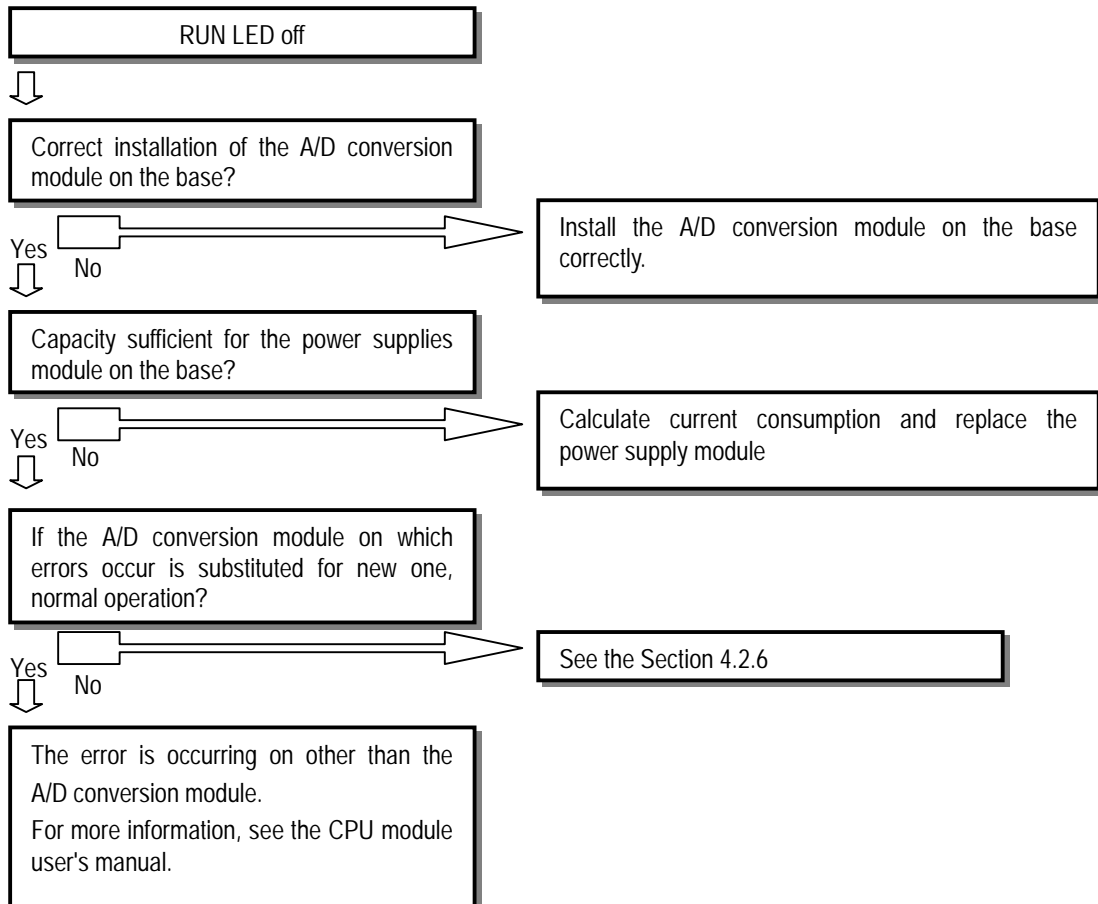

4.2.3 Digital Value Unreadable from the CPU Module

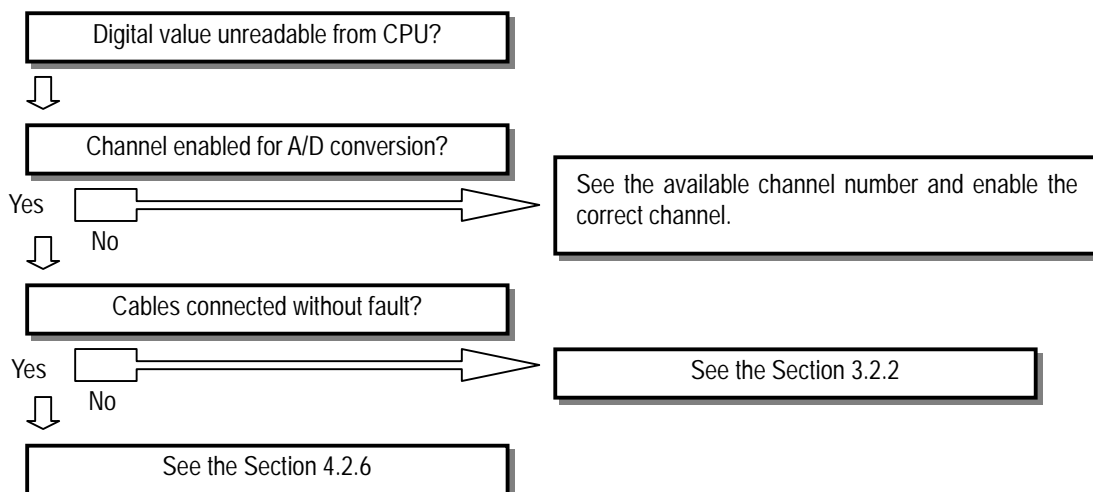

4.2.4 Sudden Digital Value Change

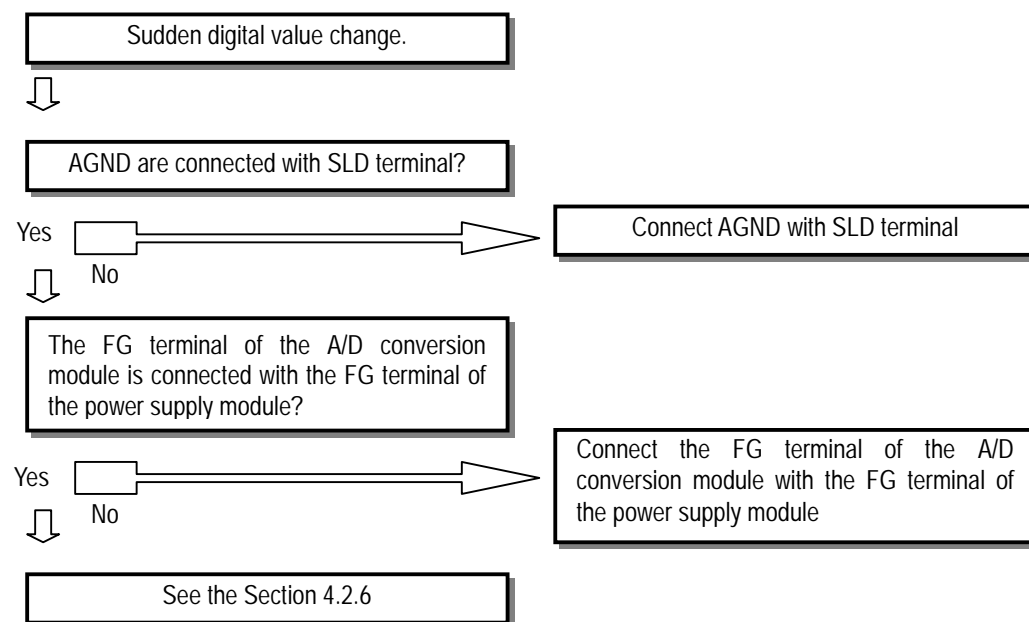

4.2.5 Analog and Digital Value Mismatch

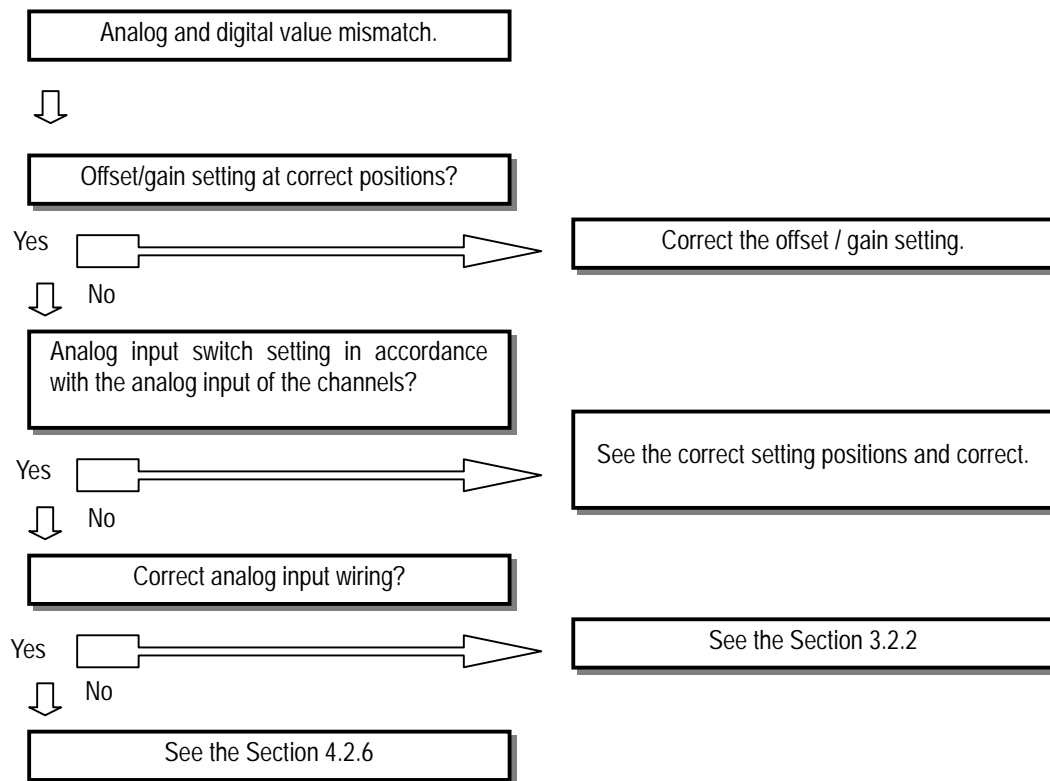

4.2.6 A/D Conversion Module Hardware Fault

A/D conversion module hardware fault.
Please contact our representatives or the service station with fault details.

Chapter 5. DIMENSIONS

5.1 G3F-AD4A Dimensions

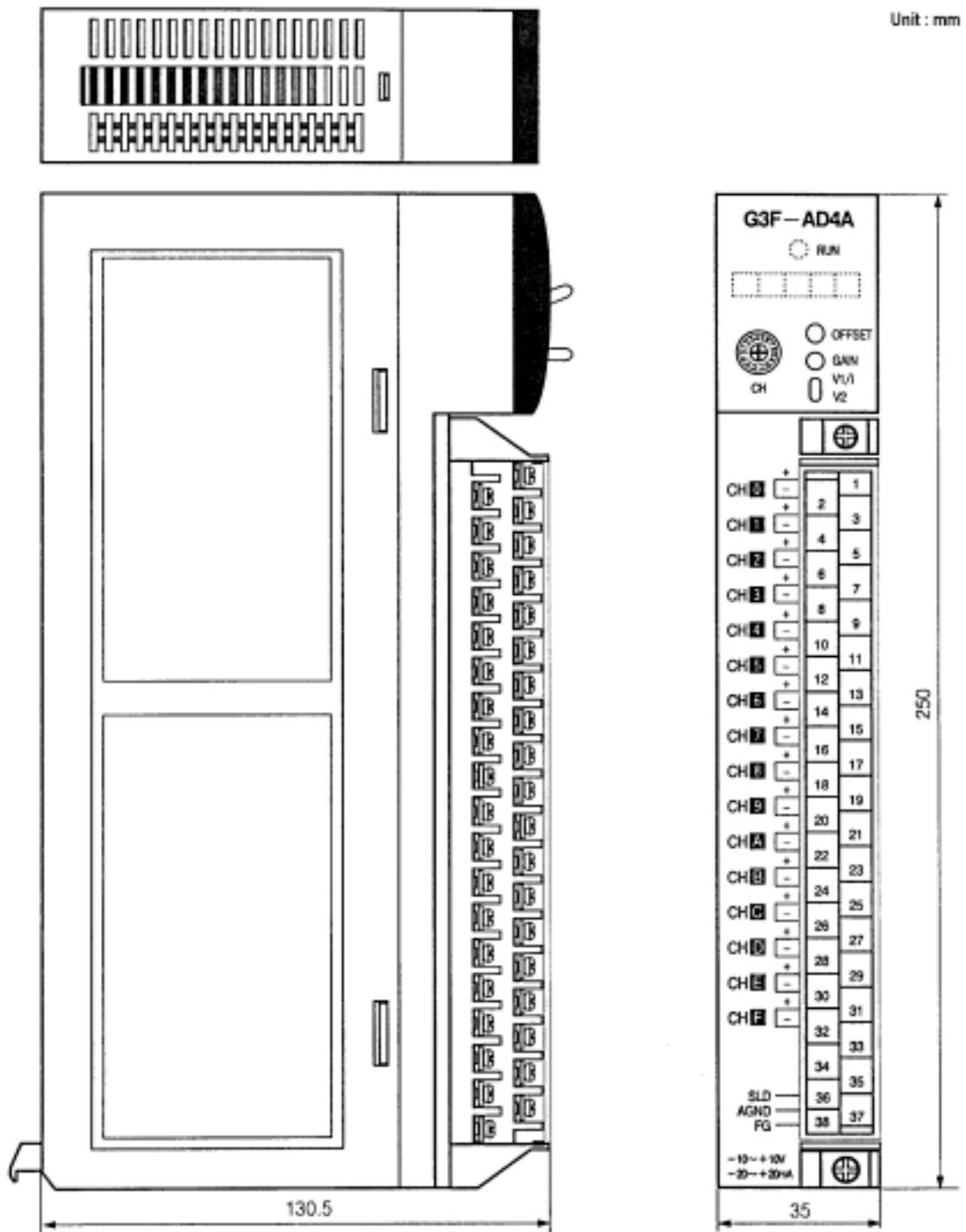

5.2 G4F-AD2A Dimensions

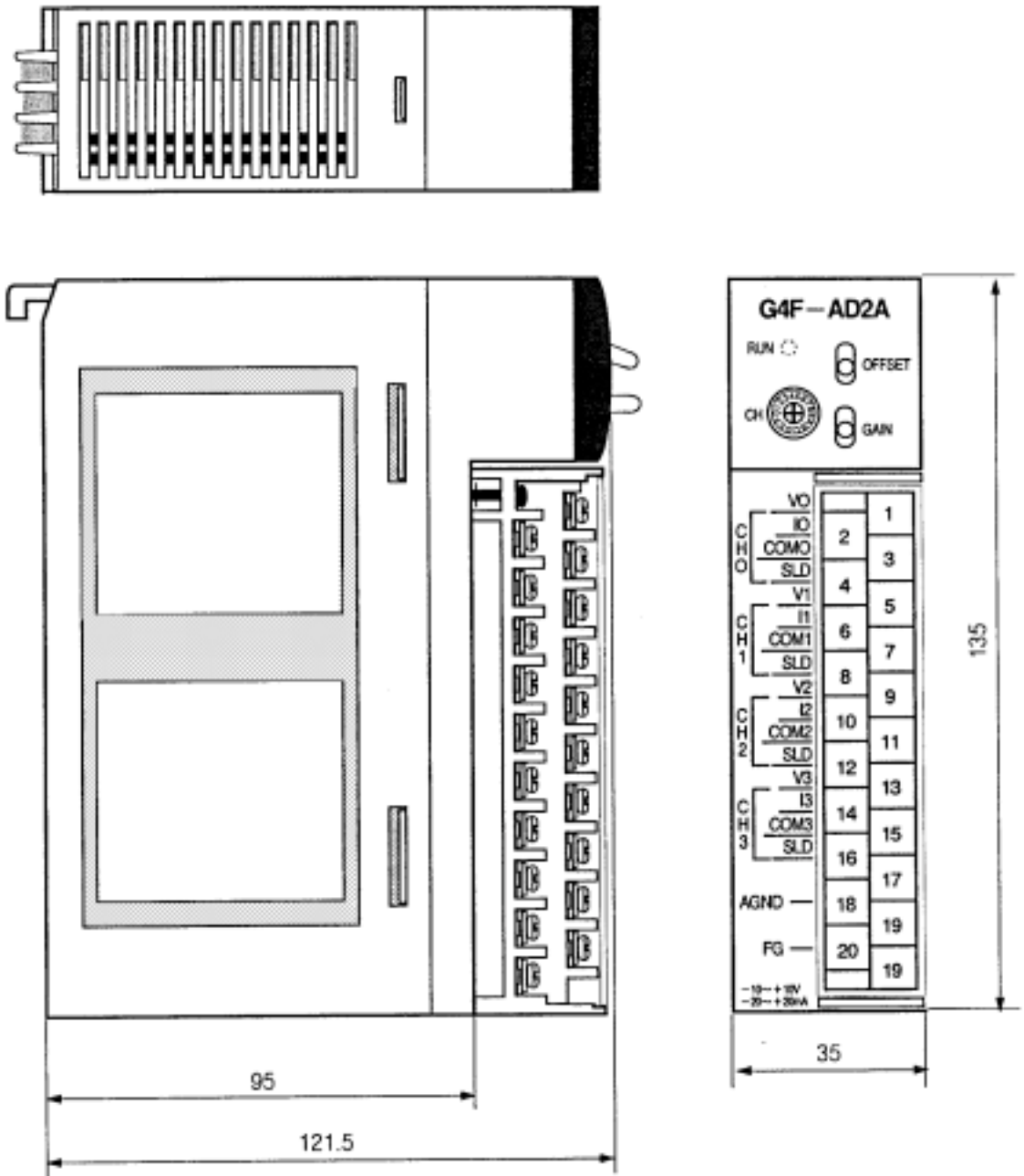

CHAPTER 6. FUNCTION BLOCK

This shows function block for A/D conversion module on the GMWIN.

A kind of function block is as follows.

No	G3F-AD4A		G4F-AD2A		Function
	Local	Remote	Local	Remote	
1	AD4INI	ADR4INI	AD2INI	ADR2INI	Initializing module
2	AD4ARD	ADR4RD	AD2ARD	ADR2RD	Reading A/D conversion value(array Type)
3	AD4RD	-	AD2RD	-	Reading A/D conversion value(Single Type)

6.1 Insertion of the Function Block for A/D Conversion Module on the GMWIN

Function Block is inserted on the execution of the GMWIN according to following procedure.

Function block can be inserted only in the open condition of the Project.

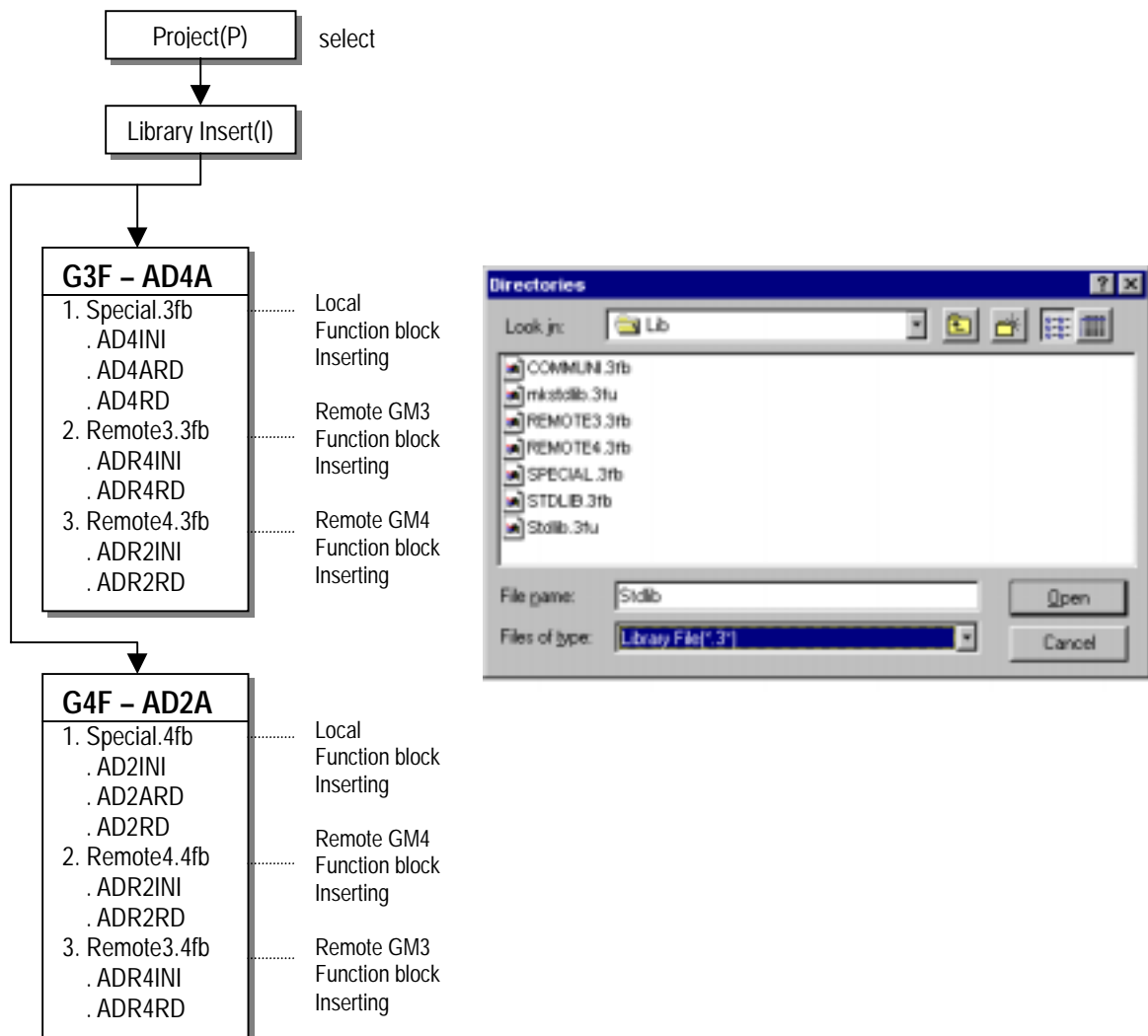

6.2 Local Function Block

6.2.1 Module Initialization : (G3F-AD4A: AD4INI, G4F-AD2A:AD2INI)

Module Initialization function block is a program for the use in setting base location number and the slot location number of an A/D conversion module, specifying an available channel enable, a data type for A/D conversion, filter processing data, and average processing data.

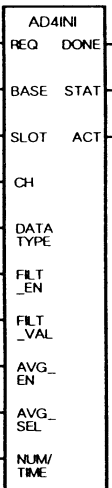
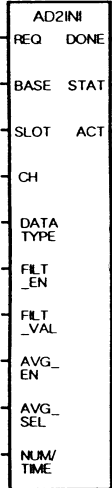
Function block	I/O	Variable	Data type	Descriptions		
G3F — AD4A 	Input	REQ	BOOL	Function Block Execution Request Area - The execution of function block initialization is requested in this area. - If the status to be connected with this area is satisfied on the program operation and input condition changes from low(0) to high(1), function block initialization for the module is executed.		
		BASE	USINT	Base Location Number Area - The base No. on which A/D conversion module is mounted is written on this area. - Setting range : GM1 series(0 to 31), GM2 series(0 to 7), GM3/4 series(0 to 3)		
		SLOT	USINT	Slot Location Number Area - The slot No. on which A/D conversion module is mounted is written on this area. - Setting range: 0 to 7		
		CH	BOOL [Array] *note1	Available Channel Specification Area - Available channels are specified in this area. - Enabled channels are specified to 1 and disabled channels are specified to 0.		
		DATA TYPE	BOOL [Array] *note1	Output Data Type Specification Area - Output digital data type for each channel is specified in this area. - 0 is for the range of -192 to 16191. - 1 is for the range of -8192 to 8191.		
		FILT_EN	BOOL [Array] *note2	Filter Processing Enable Specification Area - 0 is for the sampling processing. - 1 is for the filter processing.		
		FILT_VAL	USINT [Array] *note2	Filter Constant Setting Area - Setting range: 1 to 99		
		AVG_EN	BOOL [Array] *note2	Average Processing Enable Specification Area - 1 is for the average processing. - 0 is for the sampling process.		
		AVG_SEL	BOOL [Array] *note2	Average process Type Specification Area - 1 is for the time average. - 0 is for the number average.		
		NUM/TIME	USINT [Array] *note2	Average Number or Average Time Set Area - The number or time is set in accordance with the average process type specified on the AVG-SEL. - Average number :2 to 4000 (count) - Average time : G3F-AD4A: 96 to12,000(ms), G4F-AD2A: 40 to 20,000(ms)		
		G4F — AD2A 	Output	DONE	BOOL	Function Block Execution Complete Area - When function block initialization is executed with no error, 1 is written and until next execution, 1 is continuing. When error occurs, 0 is written and operation come to stop.
				STAT	USINT	Error Code Display Area - When error occurs during function block initialization, the error code number is written. - Error code is referred to GM Section 1.4.
				ACT	BOOL [Array] *note1	Channel Operation Display Area - The channel specified after executing the function block initialization with no error is right, 1 is written and, on the non-specified channel, 0 is written.

REMARK

*note 1 : The number of array is G3F-AD4A of 16 and G4F-AD2A of 4 .

*note 2 : The number of array is 4.

On the G3F-AD4A, the element number (0) is specified to channel 0, 1, 2, 3 in block,
the element number (1) is specified to channel 4, 5, 6, 7, in block.
the element number (2) is specified to channel 8, 9, 10, 11 in block.
the element number (3) is specified to channel 12, 13, 14, 15 in block.

On the G4F-AD2A, the element numbers means the channel ones.

6.2.2 Module Reading-Array Type : (G3F-AD4A: AD4ARD, G4F-AD2A: AD2ARD)

Array type of function block for reading the module is performed for every channel in block and the specified channels are used to read output variable of data displayed from A/D conversion digital value.

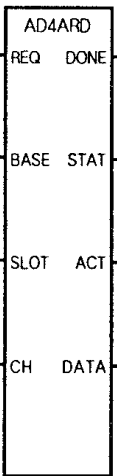
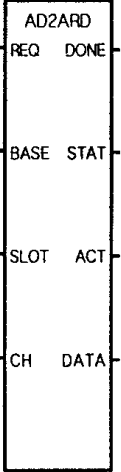
Function Block	I/O	Variable	Data type	Descriptions
G3F-AD4A 	Input	REQ	BOOL	Function Block Execution Request Area - The execution of function block reading is requested in this area. - If the status to be connected with this area is satisfied on the program operation and input condition changes from low(0) to high(1), function block initialization for the module is executed.
		BASE	USINT	Base Module Location Number Area - The base No. on which A/D conversion module is mounted is written on this area. - Setting range : GM1 series(0 to 31), GM2 series(0 to 7), GM3/4 series(0 to 3)
		SLOT	USINT	Slot Location Number Area - The slot No. on which A/D conversion module is mounted is written on this area. - Setting range: 0 to 7
		CH	BOOL [Array] *note1	Available Channel Specification Area - Available channels are specified in this area. - Enabled channels are specified to 1 and disabled channels are specified to 0.
G4F-AD2A 	output	DONE	BOOL	Function Block Execution Complete Area - When function block reading is executed with no error, 1 is written and until next execution, 1 is continuing. When error occurs, 0 is written and operation come to stop
		STAT	USINT	Error Code Display Area - When error occurs during function block reading, the error code number is written. - Error code is referred to GM Section 1.4.
		ACT	BOOL [Array] *note1	Channel Operation Display Area - The channel specified after executing the function block read with no error is right, 1 is written and, on the non-specified channel, 0 is written
		DATA	INT [Array] *note1	A/D Conversion Value Output Area

REMARK

*note 1: The number of array is G3F-AD4A of 16 and G4F-AD2A of 4 .

6.2.3 Module Reading - Single Type : (G3F-AD4A :AD4RD, G4F-AD2A:AD2RD)

Single type of function block for reading the module is performed for only one channel and the specified channel is used to read output variable of data displayed from A/D conversion digital value.

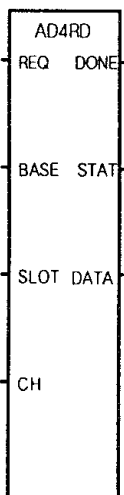
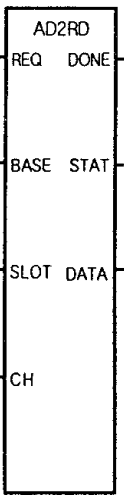
Function Block	I/O	Variable	Data type	Descriptions
G3F-AD4A 	Input	REQ	BOOL	Function Block Execution Request Area - The execution of function block reading is requested in this area. - If the status to be connected with this area is satisfied on the program operation and input condition changes from low(0) to high(1), function block initialization for the module is executed.
		BASE	USINT	Base Module Location Number Area - The base No. on which A/D conversion module is mounted is written on this area. - Setting range : GM1 series(0 to 31), GM2 series(0 to 7), GM3/4 series(0 to 3)
		SLOT	USINT	Slot Location Number Area - The slot No. on which A/D conversion module is mounted is written on this area. - Setting range: 0 to 7
		CH	USINT	Available Channel Specification Area - Available channels are specified in this area. - Setting range: 0 to 15 (G4F-AD2A: 0 to 3)
G4F-AD2A 	output	DONE	BOOL	Function Block Execution Complete Area - When function block reading is executed with no error, 1 is written and until next execution, 1 is continuing. When error occurs, 0 is written and operation come to stop.
		STAT	USINT	Error Code Display Area - When error occurs during function block initialization, the error code number is written. - Error code is referred to GM Section 1.4.
		DATA	INT	A/D Conversion Value Output Area

6.3 Remote Function Block

6.3.1 Module Initialization : (G3F-AD4A : ADR4INI, G4F-AD2A : ADR2INI)

Module Initialization function block is a program for the use in setting the location number of the slot in which the communication module of A/D conversion module of the master station is mounted, the address number of communication module which a remote I/O station has, the base location number, and the slot location number, and specifying the an available channel enable, a data type for A/D conversion, filter process data, and average process data.

Function Block	I/O	Variable	Data type	Descriptions		
G3F-AD2A AD4INI REQ NDR NET_ ERR NO ST_N STAT O BASE ACT SLOT CH DATA TYPE FILT_ EN VAL AVG_ EN SEL NUM/ TIME	Input	REQ	BOOL	Function Block Execution Request Area on Rising Edge. - The execution of write function block is requested in this area. - If the status to be connected with this area is satisfied on the program operation and input condition changes from low(0) to high(1), function block initialization for the module is executed.		
		NET_NO	USINT	The location number of the slot on which the transmission module of the master station is mounted. -Setting range: 0 to 7		
		ST_NO	USINT	Station number of the communication module which a remote I/O station has. - Setting range : 0 to 63		
		BASE	USINT	Base Location Number Area - The base No. on which A/D conversion module is mounted is written on this area. - Setting range : 0 to 3		
		SLOT	USINT	Slot Location Number Area - The slot No. on which A/D conversion module is mounted is written on this area. - Setting range: 0 to 7		
		CH	BOOL [Array] *note1	Available Channel Specification Area - Available channels are specified in this area. - Enabled channels are specified to 1 and disabled channels are specified to 0.		
		DATA TYPE	BOOL [Array] *note1	Output Data Type Specification Area - Output digital data type for each channel is specified in this area. - 0 is for the range of -192 to 16191. - 1 is for the range of -8192 to 8191.		
		FILT_EN	BOOL [Array] *note2	Filter Process Enable Specification Area - 0 is for the sampling processing. - 1 is for the filter processing.		
		FILT_VAL	USINT [Array] *note2	Filter Constant Setting Area - Setting range: 1 to 99		
		AVG_EN	BOOL [Array] *note2	Average Process Enable Specification Area - 1 is for the average processing. - 0 is for the sampling process.		
		AVG_SEL	BOOL [Array] *note2	Average process Type Specification Area - 1 is for the time average. - 0 is for the number average.		
		NUM/TIME	USINT [Array] *note2	Average Number or Average Time Set Area - The number or time is set in accordance with the average process type specified on the AVG-SEL. - Average number : 2 to 4000 (count) - Average time : G3F-AD4A: 96 to 12,000(ms), G4F-AD2A: 40 to 20,000(ms)		
		G4F-AD2A ADR2INI REQ NDR NET_ ERR NO ST_N STAT O BASE ACT SLOT CH DATA TYPE FILT_ EN VAL AVG_ EN SEL NUM/ TIME	Output	NDR	BOOL	When function block execution is completed with no error, 1 is written. During the scan which the execution condition has been made, 1 is continuing and at the next scan, 0 is written.
				ERR	BOOL	Error Data Display Area - When error occurs during function block initialization, 1 is written and the operation comes to stop. During the scan which the execution condition has been made, 1 is continuing and at the next scan, 0 is written.
STAT	USINT			Error Code Display Area - When error occurs during function block initialization, the error code number is written. - Error code is referred to GM Section 1.4.		
ACT	BOOL [Array] *note1			Channel Operation Display Area - The channel specified after executing the function block initialization with no error is right, 1 is written and, on the non-specified channel, 0 is written.		

REMARK

*note 1 : The number of array is G3F-AD4A of 16 and G4F-AD2A of 4 .

*note 2 : The number of array is 4.

On the G3F-AD4A, the element number (0) is specified to channel 0, 1, 2, 3 in block,
the element number (1) is specified to channel 4, 5, 6, 7, in block.
the element number (2) is specified to channel 8, 9, 10, 11 in block.
the element number (3) is specified to channel 12, 13, 14, 15 in block.

On the G4F-AD2A, the element numbers means the channel ones.

6.3.2 Module Reading (G3F-AD4A: AD4ARD, G4F-AD2A:ADR2RD)

Function block for reading the module is performed for every channel in block and the specified channels are used to read output variable of data displayed from A/D conversion digital value.

Function Block	I/O	Variable	Data type	Descriptions
G3F-AD4R <div style="border: 1px solid black; padding: 2px; margin: 5px;"> ADR4RD REQ NDR NET_ ERR NO STAT ST_N O BASE ACT SLOT DATA CH </div>	Input	REQ	BOOL	Function Block Execution Request Area - The execution of read function block is requested in this area. - If the status to be connected with this area is satisfied on the program operation and input condition changes from low(0) to high(1), function block reading for the module is executed.
		NET_NO	USINT	The location number of the slot on which the communication module of the master station is mounted. - Setting range: 0 to 7
		ST_NO	USINT	The station number of the communication module which a remote I/O station has. - Setting range : 0 to 63
		BASE	USINT	Base Module Location Number Area - The base No. on which A/D conversion module is mounted is written on this area. - Setting range : 0 to 3
		SLOT	USINT	Slot Location Number Area - The slot No. on which A/D conversion module is mounted is written on this area. - Setting range: 0 to 7
		CH	BOOL [Array] *note1	Available Channel Specification Area - Available channels are specified in this area. - Enabled channels are specified to 1 and disabled channels are specified to 0.
		G4F-AD2A <div style="border: 1px solid black; padding: 2px; margin: 5px;"> ADR2RD REQ NDR NET_ ERR NO STAT ST_N O BASE ACT SLOT DATA CH </div>	Output	NDR
ERR	BOOL			Error Data Display Area - When error occurs during the execution of function block reading, 1 is written and the operation comes to stop. During the scan which the execution condition has been made, 1 is continuing and at the next scan, 0 is written.
STAT	USINT			Error Code Display Area - When error occurs during the execution of function block reading, the error code number is written. - Error code is referred to GM Section 1.4.
ACT	BOOL [Array] *note1			Channel Operation Display Area -The channel specified after executing the function block reading with no error is right, 1 is written and, on the non-specified channel, 0 is written.
DATA	INT [Array] *note1			A/D Conversion Value Output Area

REMARK

*note 1: The number of array is G3F-AD4A of 16 and G4F-AD2A of 4 .

6.4 Errors on Function Block

This shows errors and resolutions in accordance with them.

STAT No.	Local /Remote	Descriptions	Function block			Resolutions	
			Initial-ization	Read			
				Array type	Single type		
0	Local	Operating with no fault	0	0	0	-	
1		The base location number is exceeding the proper setting range	0	0	0	Correct the number in accordance with the proper range (See GM Section1.2)	
2		H/W error of the base	0	0	0	Contact the service station	
3		The slot location number is exceeding the proper setting range	0	0	0	Set the right number to the slot loading the A/D conversion module	
4		The A/D conversion module on the slot is empty	0	0	0	Load the A/D conversion module to the specified slot	
5		The module loaded isn't the A/D module	0	0	0	Load the A/D conversion module to the specified slot	
6		The channel number is exceeding the proper range	-	-	0	Specify the available channel correctly	
7		H/W error of the A/D conversion module	0	0	0	Contact the service station	
8		The A/D conversion module's shared memory error	0	0	0	Contact the service station	
9		The available channels are not specified	-	0	0	Make a correct specification of the available channel on the initialize function block	
10		Test mode	-	0	0	Transmit the test mode to normal mode (G4F-AD2A only)	
16		Filter value exceeding the proper range	0	-	-	Correct the value to the range of 1 to 99	
17		Average number/time value exceeding the proper range	0	-	-	Correct the value to the proper range (Number: 2 to 4,000 Time: G3F-AD4A 96 to 12,000(ms) G4F-AD2A 40 to 20,000(ms))	
128		Remote	H/W error of the communication module for remote	0	0	-	See the manual for the remote communication module
129			The base location number is exceeding the proper setting range	0	0	-	Correct the number in accordance with the proper range (See GM Section 1.2)
131			The slot location number is exceeding the proper setting range	0	0	-	Set the right number to the slot mounting the A/D conversion module
133			The module loaded isn't the A/D module	0	0	-	Mount the A/D conversion module to the specified slot
135	H/W error of the A/D conversion module		0	0	-	Contact the service station	
136	The A/D conversion module's shared memory error		0	0	-	Contact the service station	
137	The available channels are not specified		-	0	-	Make a correct specification of the available channel on the initializing function block	
138	Test mode		-	0	-	Transmit the test mode to normal mode (G4F-AD2A only)	
144	Filter value exceeding the proper range		0	-	-	Correct the value to the range of 1 to 99	
145	Average number/time value exceeding the proper range		0	-	-	Correct the value to the proper range (Number: 2 to 4,000 Time: G3F-AD4A 96 to 12,000(ms) G4F-AD2A 40 to 20,000(ms))	

Chapter 7. PROGRAMMING

7.1 Programming for Distinction of A/D Conversion Value

1) System Configuration

GM3-PA1A	GM3-CPUA	G3F-AD4A	G3Q-RY4A
----------	----------	----------	----------

2) Initial Settings

- (1) Available channel enable : channel 0, 2, 4
- (2) Conversion data range: -192 to 16191(channel 0, 2, 4)
- (3) Filter channel enabled : channel 0
- (4) Filter constant setting : channel 0 = 50
- (5) Average processing setting : channel 2, 4
- (6) Number average setting and set value : channel 2 = 100 count
- (7) Time average setting and set value : channel 4 = 200 ms
- (8) Analog input : current input(DC -20 ~ 20 mA)

3) Descriptions of the Program

- (1) The digital value less than 12,000 of channel 0 turns %Q0.1.0 on.
- (2) The digital value more than 13,600 of channel 2 turns %Q0.1.1 on.
- (3) The digital value more than 12,000 or same, and less than 13,600 or same of channel 4 turns %Q0.1.2 on.
- (4) The digital value of the same as 12,800 of channel 4 turns %Q0.1.3 on.

REMARK

- In the Initial setting

- 1) At the part of (3), if channel 0 is enabled to the filter processing, channel 0 to 3 will be enabled to the filter processing in block.
- 2) At the part of (4), if channel 0 is enabled to the filter constant, channel 0 to 3 will be enabled to the filter constant of 50 in block.
- 3) At the part of (5), if channel 2 and 4 are enabled to the average processing, channel 0 to 3 and 4 to 7 will be enabled to the average processing in block.
- 4) At the part of (6), if channel 2 is enabled to the number average value of 100, channel 0 to 3 will be enabled to the number average value of 100 in block.
- 5) At the part of (7), if channel 4 is enabled to the time average value of 200ms, channel 4 to 7 will be enabled to the time average value of 200 ms in block.

4) Programming Example

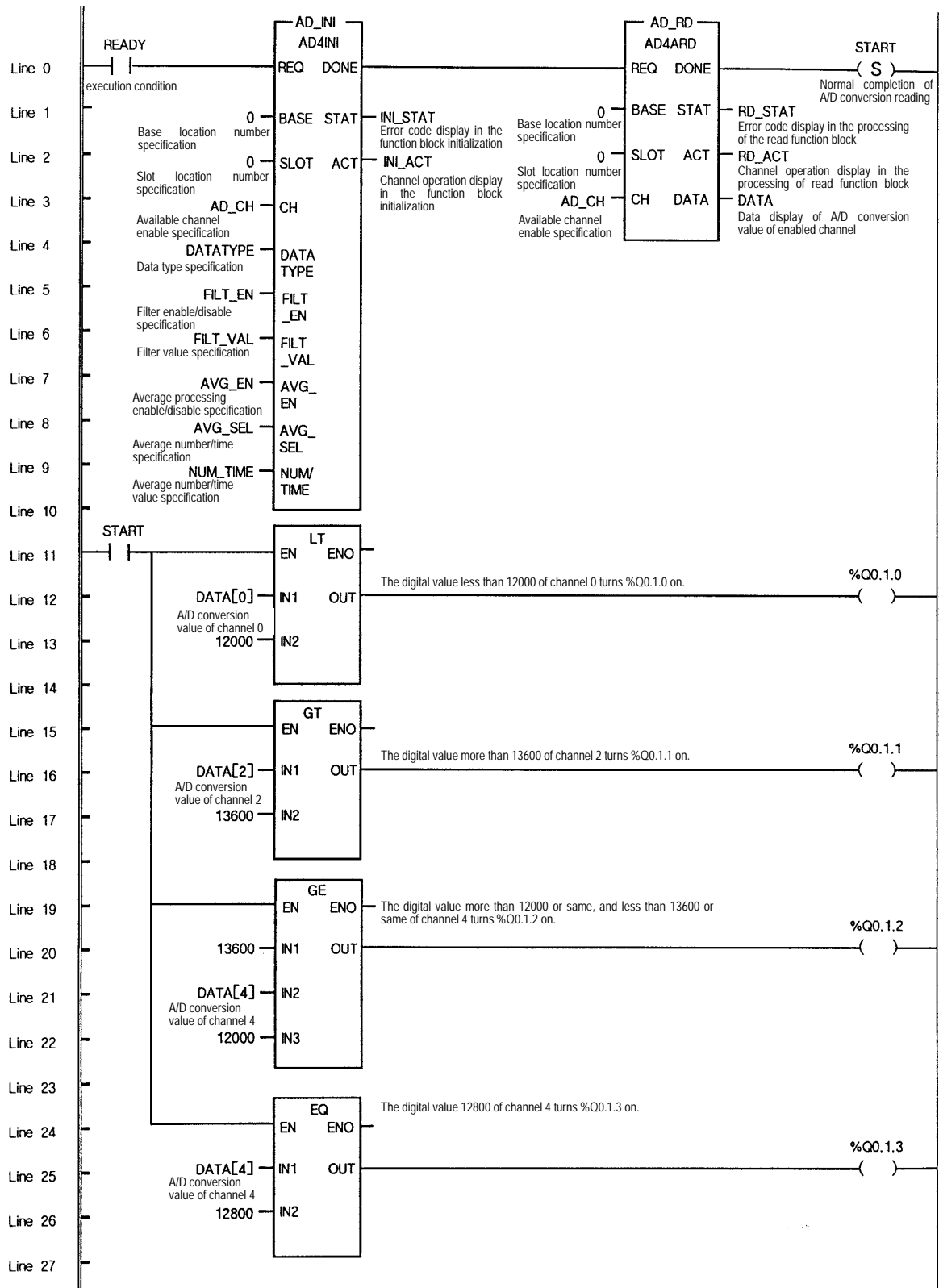

5) Specifying initial value of input/output variables on the program.

(1) Specifying channels

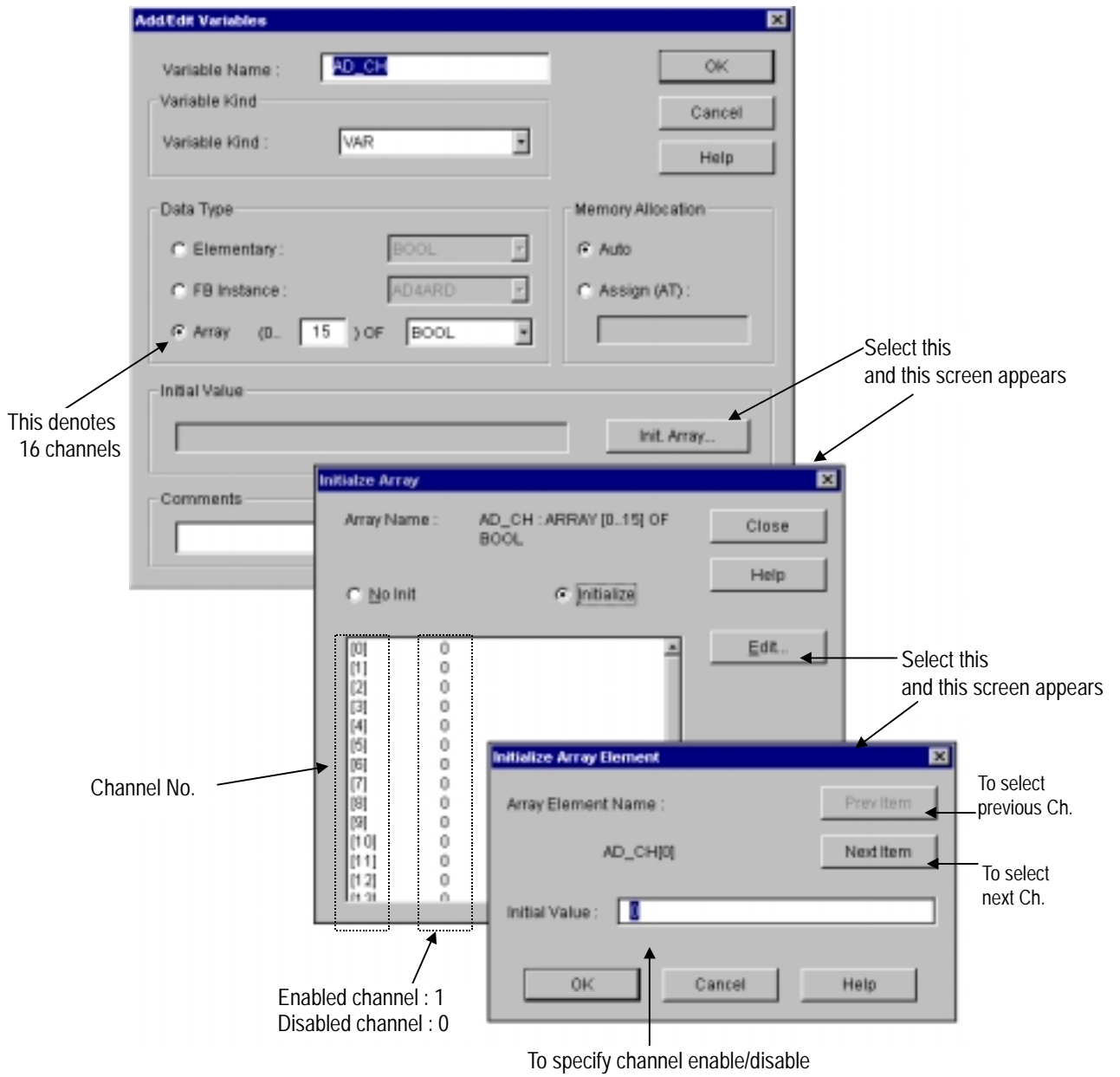

(2) Specifying filter enable/disable

To specify G3F-AD4A channel 0,1,2, 3 in block → [0]

To specify G3F-AD4A channel 4,5,6,7 in block → [1]

To specify G3F-AD4A channel 8,9,10,11 in block → [2]

To specify G3F-AD4A channel 12,13,14,15 in block → [3]

Filter enable : 1
Filter disable : 0

To specify filter enable/disable

6) Input/output variables on Programming

Variable Name	Var_Kind	Data Type	(AT Address) (Initial Value)
AD_CH	: VAR	: ARRAY [0..15] OF BOOL	: = { 1,0,1,0,1,0,0,0,0,0,0,0,0,0,0 }
AD_INI	: VAR	: FB instance	
AD_RD	: VAR	: FB instance	
AVG_EN	: VAR	: ARRAY [0..3] OF BOOL	: = { 1,1,0,0 }
AVG_SEL	: VAR	: ARRAY [0..3] OF BOOL	: = { 0,1,0,0 }
DATA	: VAR	: ARRAY [0..15] OF INT	
DATATYPE	: VAR	: ARRAY [0..15] OF BOOL	: = { 0,0,0,0,0,0,0,0,0,0,0,0,0,0,0 }
FILT_EN	: VAR	: ARRAY [0..3] OF BOOL	: = { 1,0,0,0 }
FILT_VAL	: VAR	: ARRAY [0..3] OF USINT	: = { 50,0,0,0 }
INI_ACT	: VAR	: ARRAY [0..15] OF BOOL	
INI_STAT	: VAR	: USINT	
NUM_TIME	: VAR	: ARRAY [0..3] OF UNIT	: = { 100,200,0,0 }
RD_ACT	: VAR	: ARRAY [0..15] OF BOOL	
RD_STAT	: VAR	: USINT	
READY	: VAR	: BOOL	
START	: VAR	: BOOL	

7.2 Programming for Display of A/D Conversion Value and Error Code on BCD Display

1) System Configuration

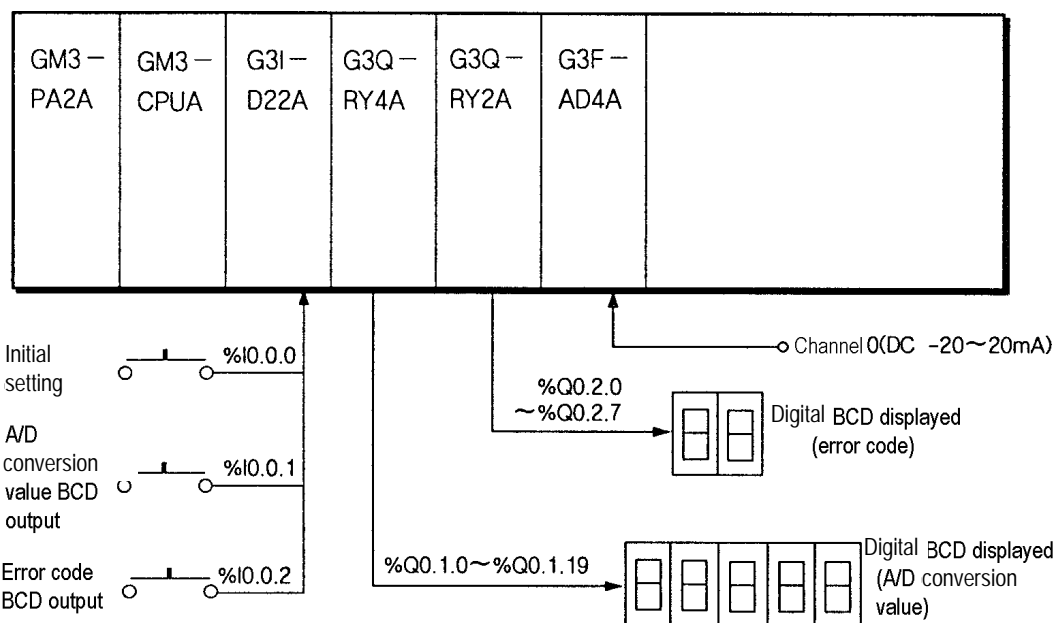

2) Initial Settings

- (1) Available channel enabled : channel 0,
- (2) Time average processing specification: 100 ms
- (3) Data output type setting: -192 to 16191
- (4) Analog input : current input(DC -20 to 20 mA)

3) Descriptions of the Program

- (1) %I0.1.0 turning On leads to the initial setting of A/D conversion module.
- (2) %I0.1.1 turning On leads to displaying A/D conversion value on the BCD display.(%Q0.1.0 to %Q0.1.19)
- (3) %I0.1.2 turning On leads to displaying error code of function block on the BCD display, (%Q0.2.0 to %Q0.2.7)

4) Programming

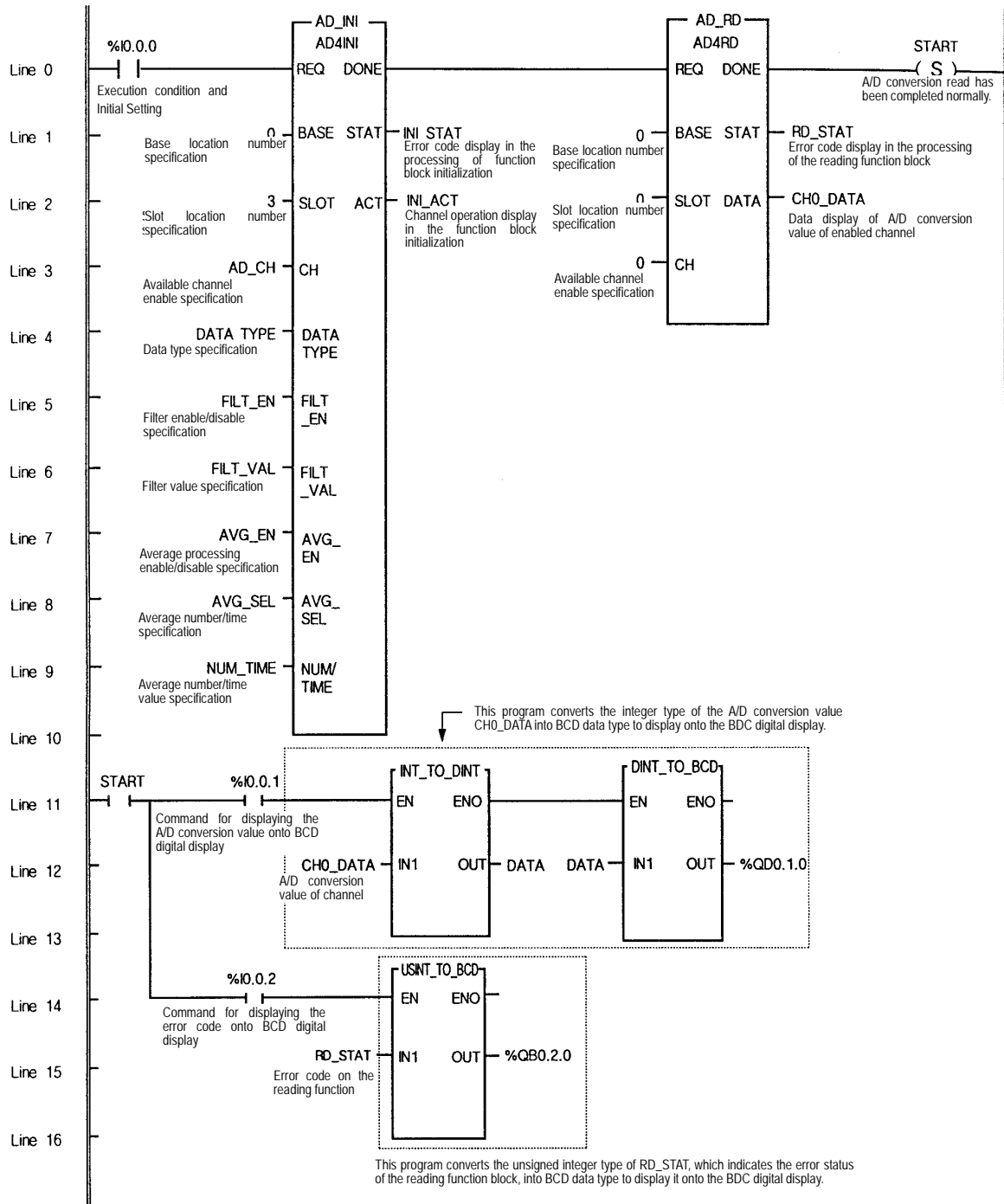

5) Input/output variables on the programming

Variable Name	Var_Kind	Data Type	(AT Address) (Initial Value)
AD_CH	: VAR	: ARRAY [0..15] OF BOOL	:= {1,0,0,0,0,0,0,0,0,0,0,0,0,0,0}
AD_INI	: VAR	: FB Instance	
AD_RD	: VAR	: FB Instance	
AVG_EN	: VAR	: ARRAY [0..3] OF BOOL	:= {1,0,0,0}
AVG_SEL	: VAR	: ARRAY [0..3] OF BOOL	:= {1,0,0,0}
CHO_DATA	: VAR	: INT	
DATA	: VAR	: DINT	
DATATYPE	: VAR	: ARRAY [0..15] OF BOOL	:= {0,0,0,0,0,0,0,0,0,0,0,0,0,0,0}
FILT_EN	: VAR	: ARRAY [0..3] OF BOOL	:= {0,0,0,0}
FILT_VAL	: VAR	: ARRAY [0..3] OF USINT	:= {0,0,0,0}
INI_ACT	: VAR	: ARRAY [0..15] OF BOOL	
INI_STAT	: VAR	: USINT	
NUM_TIME	: VAR	: ARRAY [0..3] OF UINT	:= {100,0,0,0}
RD_STAT	: VAR	: USINT	
START	: VAR	: BOOL	

7.3 Programming for Loading the A/D Conversion Module on Remote I/O Station

1) System Configuration

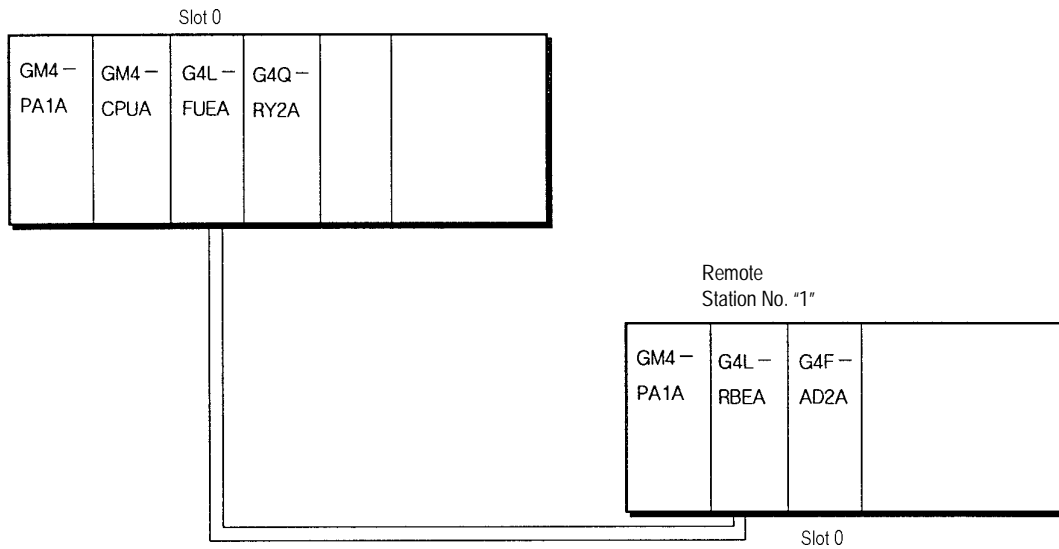

2) Initial Settings

- (1) A/D conversion enabling channel: channel 0
- (2) Conversion data range: -192 to 16191
- (3) Time average processing channel: channel 0 (setting value: 1,000 ms)

3) Descriptions of the Program

- (1) The digital value less than 8000 of channel 0 turns %Q0.1.0 on.
- (2) The digital value more than 8000 or same, and less than 10,000 or same of channel 0 turns %Q0.1.1 on.
- (3) The digital value more than 10,000 or same, and less than 12,000 of channel 0 turns %Q0.1.2 on.
- (4) The digital value more than 12,000 or same of channel 0 turns %Q0.1.3 on.

4) Programming example

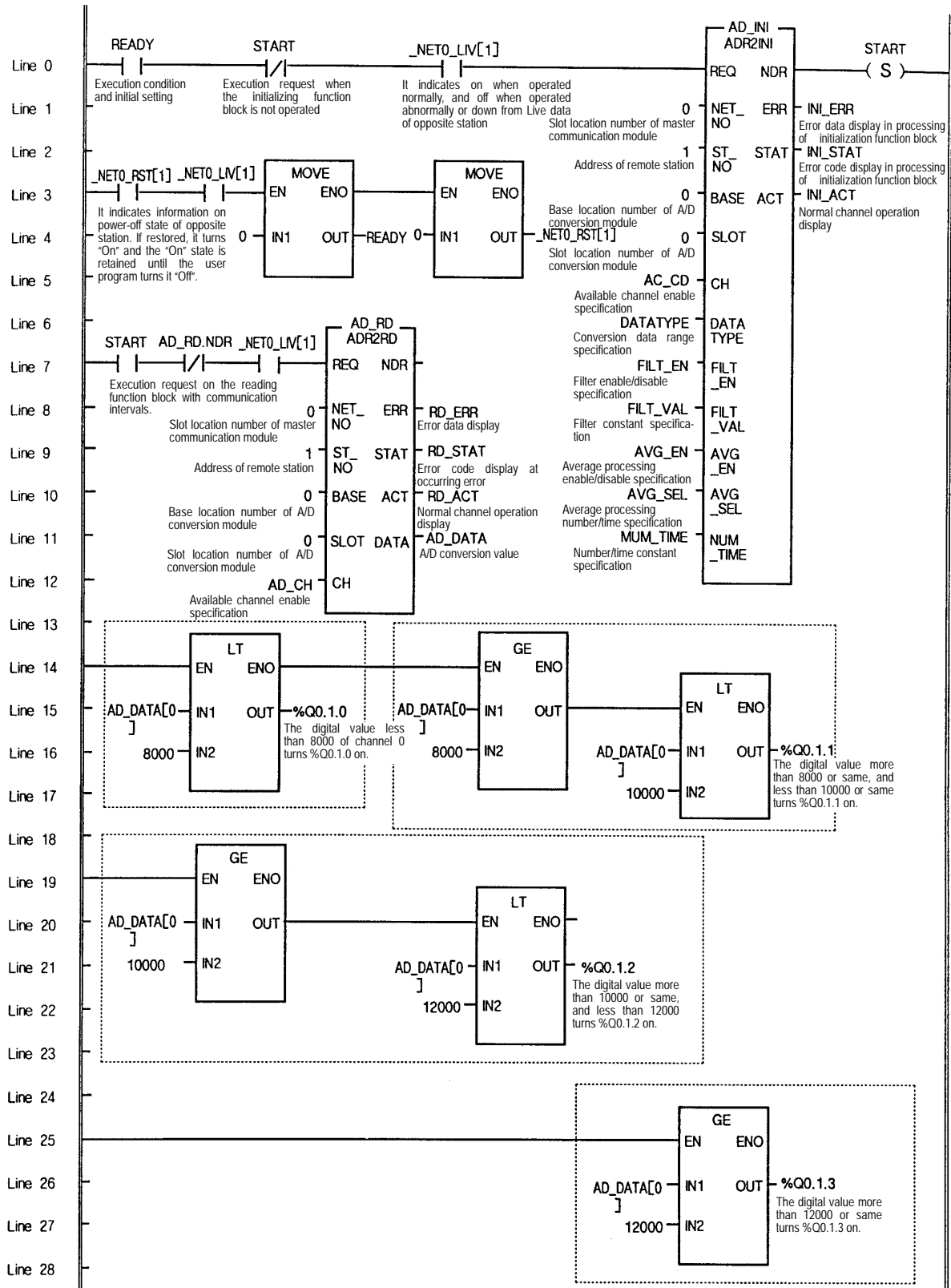

5) Input/output variables used on the programming

Variable Name	Var_Kind	Data Type	(AT Address) (Initial Value)
AD_CH	: VAR	: ARRAY [0..3] OF BOOL	:= {0,0,0,0}
AD_DATA	: VAR	: ARRAY [0..3] OF INT	
AD_INI	: VAR	: FB Instance	
AD_RD	: VAR	: FB Instance	
AVG_EN	: VAR	: ARRAY [0..3] OF BOOL	:= {1,0,0,0}
AVG_SEL	: VAR	: ARRAY [0..3] OF BOOL	:= {1,0,0,0}
DATATYPE	: VAR	: ARRAY [0..3] OF BOOL	:= {0,0,0,0}
FILT_EN	: VAR	: ARRAY [0..3] OF BOOL	:= {0,0,0,0}
FILT_VAL	: VAR	: ARRAY [0..3] OF USINT	:= {0,0,0,0}
INI_ACT	: VAR	: ARRAY [0..3] OF BOOL	
INI_ERR	: VAR	: BOOL	
INI_STAT	: VAR	: USINT	
NUM_TIME	: VAR	: ARRAY [0..3] OF UINT	:= {1000,0,0,0}
RD_STAT	: VAR	: ARRAY [0..3] OF BOOL	
RD_ERR	: VAR	: BOOL	
RD_STAT	: VAR	: USINT	
READY	: VAR	: BOOL	